

ams[®]

**Measuring
Technology...**

analogue and digital

**Our Experience
Is Your Success**

analogue and digital
measuring technology
current transformers
energy management

shunts

transducers

bus bar insulators and supports

**laboratory &
teaching aids**

Development
Production
Sales
Tradition

CATALOGUE 2025/26

Get In Touch With AMS:



Address:

Enge Gasse 1 · D-91275 Auerbach
P/O Box 1180 · D-91270 Auerbach

Phone +49 (0) 96 43 / 92 05-0
Telefax +49 (0) 96 43 / 92 05-90

Internet: www.ams-messtechnik.de
E-mail: info@ams-messtechnik.de

Next train stations:
Neuhaus / Pegnitz

Next airport:
Nürnberg

By car:
motorway A9 (Nürnberg - Berlin),
exit Grafenwöhr

ams[®]

General Information

Our meters comply with the "Rules For Electric / Electronic Meters", VDE 0410/3.68. For the majority of these meters DIN EN 61010-1 is applied.

The definitions and technical specifications base on the VDE-Rule.

Construction and design are subject to change without notice. In case of changes of drawings, dimensions and pictures this document won't be seized.

Technical Design

Housing:

Square front-mounted or rear-mounted instruments. Edgewise and slim-line meters. Panel-mounted meters compliant with DIN 43718 s.

Zero position:

All meters contain an adjusting screw for the zero position - accessible from outside.

Pointer:

Panel-mounted meters are fitted with a knife-edge pointer compliant with DIN 43802.

All other instruments are fitted with a tube pointer.

Scales:

For scales of panel-mounted meters a division with bold lines for main values compliant with DIN 43802 is used.

Other scales can be adjusted according to the norm or to all technically feasible customer requests.

Measuring ranges:

The end values are staggered compliant to DIN 43701 as follows:

1 – 1.5 – 2.5 – 4 – 6, decimal parts or multiples.

For moving iron meters with transformer connection also possible:

1 – 1.2 – 1.5 – 2 – 2.5 – 3 – 4 – 5 – 6 – 7.6 – 8.

Accuracy

Measuring instruments compliant to VDE 0410/3.68 have one of the following accuracy classes: 0.5 – 1 – 1.5 – 2.5 – 5. The accuracy class shows which percentage of the end value is accepted as measuring error. If the zero position is not at the beginning of the scale (e.g. central zero), the 'end value' will be the sum of both positive and negative range.

General Information

Technical Statements

Operating temperature:

Class 1 to 5 meters work fault-free at a temperature between -20°C and $+40^{\circ}\text{C}$.

Temperature influence:

Unless stated differently the nominal temperature is $+20^{\circ}\text{C}$ with a tolerance of $\pm 2\text{ K}$ for class 1 to 5 meters. Nominal usage range is the reference temperature $\pm 10\text{ K}$. The additional error within this temperature range must be smaller than the class accuracy.

Mounting position influence:

Nominal mounting position according to the mounting symbol (see page V) $\pm 5^{\circ}$.

Magnetic influence:

With the usage of core magnet movements and the magnetic shielding of the moving iron coils the magnetic influence is below accepted levels. Information about strong external magnetic fields (e.g. ferromagnetic mounting panels) can be useful for further reducing this influence though.

Testing voltage:

The test of voltage resistance is done according to the currently valid DIN norm.

Permanent overload capacity:

Class 1 to 5 current- and voltage meters can be permanently overloaded by the 1.2 fold of the end value at a temperature of 20°C (nominal temperature respectively).

General Information

Electrical shock resistance:

Class 1 to 5 meters are type tested with nine peaks of 0.5 seconds duration each and one peak of 5 seconds duration. The time between two peaks is one minute.

For ammeters the peaks are tenfold the end value, for voltage meters they are twice the end value.

Resistance to vibration:

Class 1 to 5 meters are type tested with an amplitude of ± 0.25 mm and a frequency of 50 Hz sinusoidal; applied in 3 mutually perpendicular planes for 20 minutes.

Mechanical shock resistance:

Class 1 to 5 meters are type tested with five shocks of 15 g in each of three mutually perpendicular directions, if possible parallel to the housing edges.

Earthquake certified version:

A selection of our meters is available with increased shock resistance "earthquake-proof".

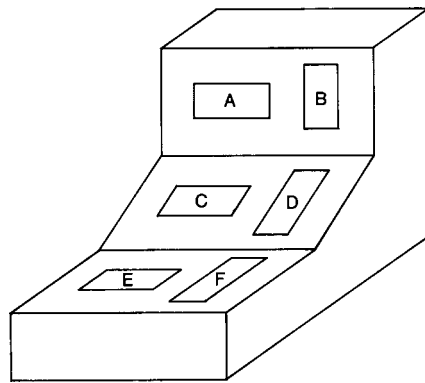













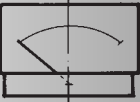

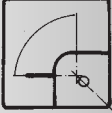







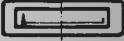

	position	format	symbol
A	vertical	landscape	┌
B	vertical	portrait	┐
C	angular	landscape	└
D	angular	portrait	┘
E	horizontal	landscape	┌
F	horizontal	portrait	┐

General Information

When ordering instruments please specify the following details:

1. Number of instruments
2. Housing size and type; switchboard instruments of the type "RQ" are delivered with slim frame by default
3. Accuracy
4. Type of **current** (AC / DC, for AC please specify the frequency if other than 50 Hz or non-sinusoidal)
5. **Measuring range** (please apply the DIN 43701 row as described on page III)
6. **Mounting position** (horizontal, vertical, angular - please specify the angle: 0° is horizontal, see figure on page V).
7. Pointer deflection 90° or 105°
8. **Scale design:** if the scale must show a different variable than the measured electrical value, we will need a graphic chart or table that specifies the relation between the non-electrical (displayed) and the electrical (measured) values. Any other than standard design according to DIN 43802 must be specified exactly, if possible by sketch or picture.
9. The calibrated **wire resistance** of moving coil ammeters for connecting to separate shunts is 0.035 Ohm by default.
10. Separate **shunts, current- or voltage transformers** are not included and have to be ordered separately.

	INTERSERIE	moving coil meters	 
	INTERSERIE	moving iron meters	 
	WIDE SCALES BIG INDICATORS	moving coil meters	 
	SQUARE MOVING COIL METERS	moving coil movement <ul style="list-style-type: none"> • "Ratio" series • steel sheet series 	  
	SQUARE MOVING IRON METERS	moving iron movement <ul style="list-style-type: none"> • "Ratio" series • steel sheet series 	 
	SQARE PANEL METERS	pointer frequency meters bimetal meters	  
	RECTANGULAR PANEL METERS	edgewise and slim-line moving coil meters	  
	SQARE PANEL METERS	power meters power factor meters	 
	SPECIAL INSTRUMENTS	operating hours counter, phase sequence indicator DIN rail meters, switch position indicators, moving coil double indicator	  
	DIGITAL INSTRUMENTS	multifunctional display AC / DC measurement electricity meter	 
	ACCESSORIES	shunts current transformers	
	TRANSDUCERS	current and voltage, frequency, power and power factor buffer amplifier, temperature, resistance	

PRODUCT LIST

The Measuring Instruments of the "Interserie"

"INTERSERIE" METERS

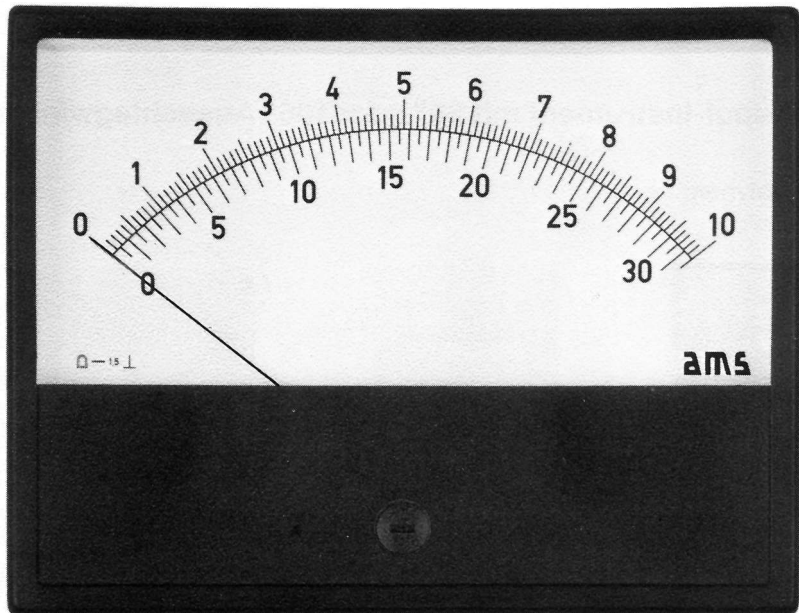

Housings



AB

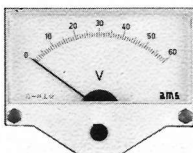

UB

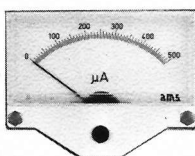

EB

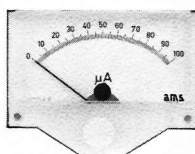

EBN

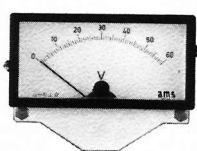

URB

- are available with moving coil core magnet movements, accuracy class 1.5 or 2.5 (class 1 on request), which are resistant against external magnetic fields.
- are available in 7 housing sizes for up to 5 built-in variations.
- are equipped with a pointer deflection of 90° or 105°.
- have interchangeable slide-in scales by default, on demand translucent or with mirror scale.
- have scales with flat or normal (360° section) arc.
- are equipped with tube pointer (knife-edge pointer on request)
- are in the built-in version 'AB' equipped with a dark grey front frame (similar to RAL 7011) by default, on demand 'light grey' and 'black' are available.
- are to a great extent optionally available with rectifier for measuring AC values.
- are available in the sizes 55 - 60 - 75 - 80 - 96 - 100 - 130

Size 55

Interserie Moving Coil Meter

90° or 105° Pointer Deflection

Available housings:

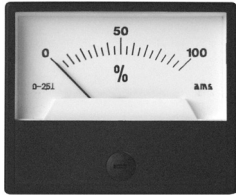

AB 55
panel mounting type

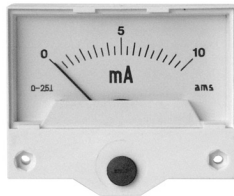

UB 55
submounting type

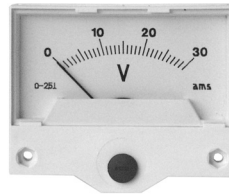

EB 55
built-in type

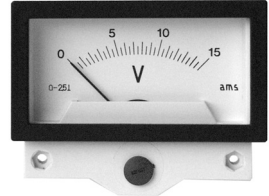

URB 55
with submounting frame

Movement

Bearing

Pointer

Accuracy class

Scale

Front frame colour

URB frame colour

moving coil with core magnet
pivots with spring mounted jewels

tube pointer

1.5 or 2.5

interchangeable slide-in scale
if fsd 90° scale length approx. 34 mm
if fsd 105° scale length approx. 40 mm

dark grey similar to RAL 7011;

light grey or black on demand

black

Measuring range

Ammeters

Internal resistance

Voltmeters

Internal resistance

100 μ A	4000 Ω	100 mV	} 1000 Ω /V
150 μ A	4000 Ω	150 mV	
250 μ A	1300 Ω	400 mV	
400 μ A	1100 Ω	600 mV	
600 μ A	380 Ω	1 V	
1 mA	70 Ω	1.5 V	
1.5 mA	30 Ω	2.5 V	
2.5 mA	13 Ω	4 V	
4 mA	11 Ω	6 V	
6 mA	5.5 Ω	10 V	
10 mA	3 Ω	15 V	
15 mA	2.8 Ω	25 V	
20 mA	2.3 Ω	40 V	
25-60 mA	60 mV	60 V	
1 A [•]	60 mV	100 V	
1.5 A [•]	60 mV	150 V	
2.5 A [•]	60 mV	250 V	
4 A [•]	60 mV	400 V	
60 mV x	12 Ω	500 V	
		600 V	

• Shunt fitted on the rear
x For operation with separate shunt
Tolerance of the internal resistance \pm 20%

Size 55 Moving Coil Meter

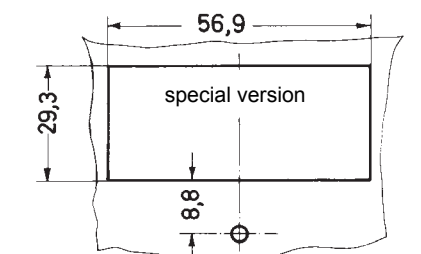
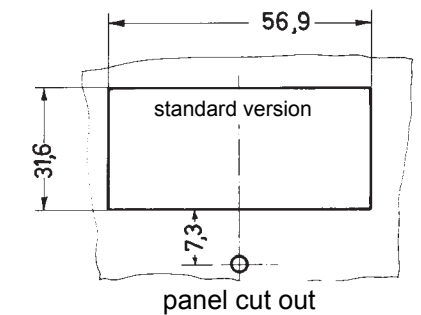
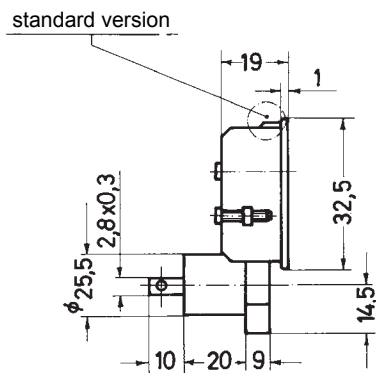
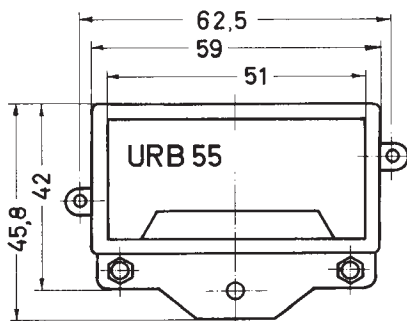
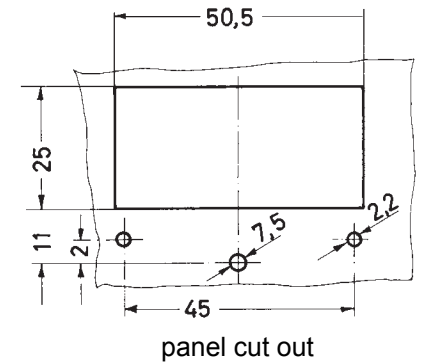
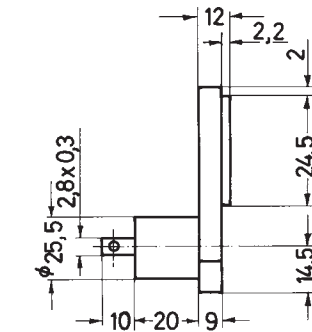
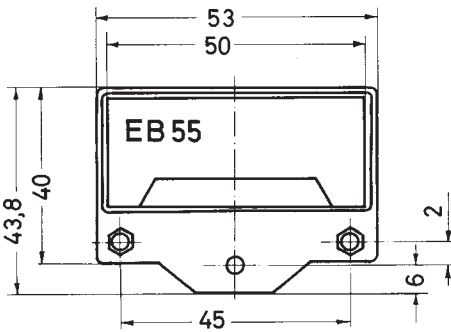
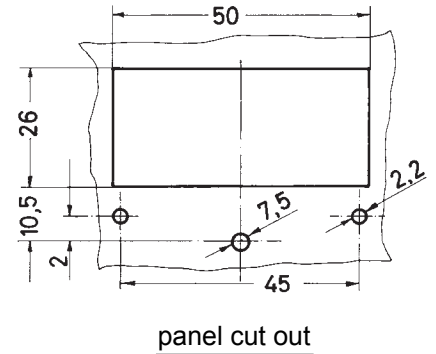
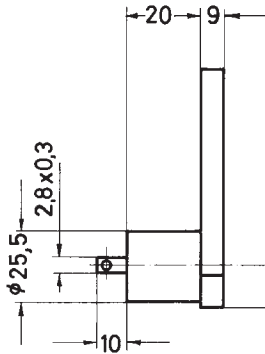
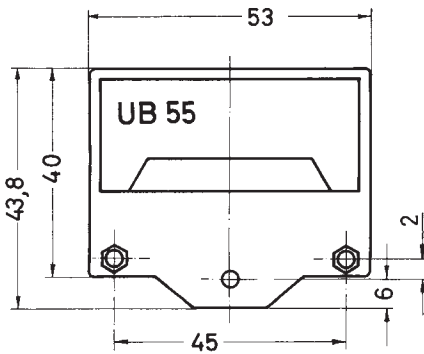
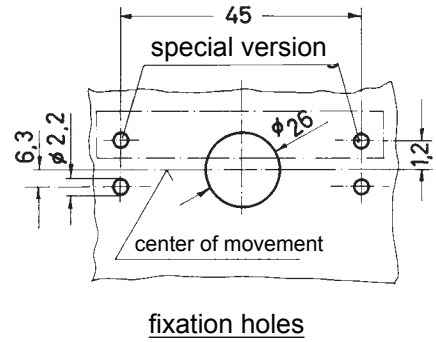
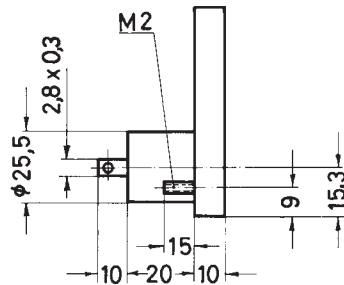
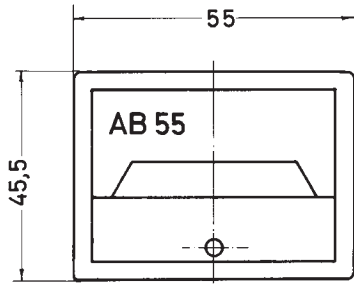

"INTERSERIE" METERS

Size 60

Interserie Moving Coil Meter

90° or 105° Pointer Deflection

Available housings:

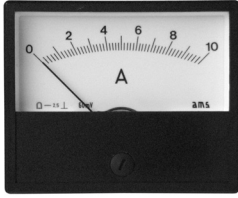

AB 60
panel mounting type

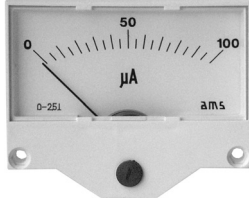

UB 60
submounting type

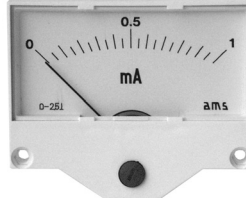

EB 60
built-in type

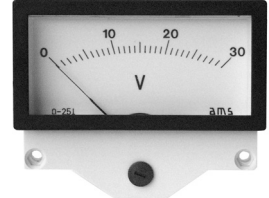

URB 60
with submounting frame

Movement	moving coil with core magnet
Bearing	pivots with spring mounted jewels
Pointer	tube pointer
Accuracy class	1.5 or 2.5
Scale	interchangeable slide-in scale if fsd 90° scale length approx. 48 mm if fsd 105° scale length approx. 54 mm
Front frame colour	dark grey similar to RAL 7011; light grey or black on demand
URB frame colour	black

Measuring range	Ammeters	Internal resistance	Voltmeters	Internal resistance
	100 µA	4000 Ω	100 mV	} 1000 Ω/V
	150 µA	4000 Ω	150 mV	
	250 µA	1300 Ω	400 mV	
	400 µA	1100 Ω	600 mV	
	600 µA	380 Ω	1 V	
	1 mA	70 Ω	1.5 V	
	1.5 mA	30 Ω	2.5 V	
	2.5 mA	13 Ω	4 V	
	4 mA	11 Ω	6 V	
	6 mA	5.5 Ω	10 V	
	10 mA	3 Ω	15 V	
	15 mA	2.8 Ω	25 V	
	20 mA	2.3 Ω	40 V	
	25-60 mA	60 mV	60 V	
	1 A [•]	60 mV	100 V	
	1.5 A [•]	60 mV	150 V	
	2.5 A [•]	60 mV	250 V	
	4 A [•]	60 mV	400 V	
	6 A [•]	60 mV	500 V	
	10 A [•]	60 mV	600 V	
	15 A [•]	60 mV		
	60 mV x	12 Ω		

• Shunt fitted on the rear
x For operation with separate shunt
Tolerance of the internal resistance ± 20%

Ammeters for direct connection of up to 30 A in housings ... 60 DE

Size 60 Moving Coil Meter

"INTERSERIE" METERS

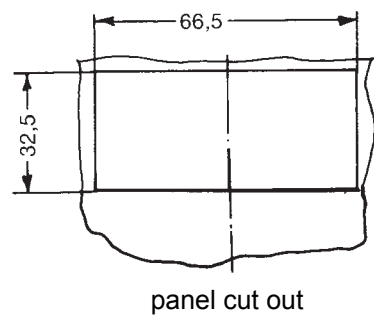
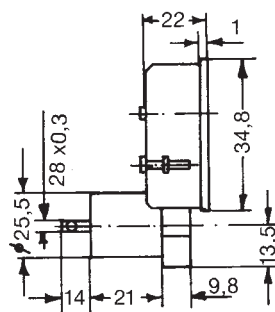
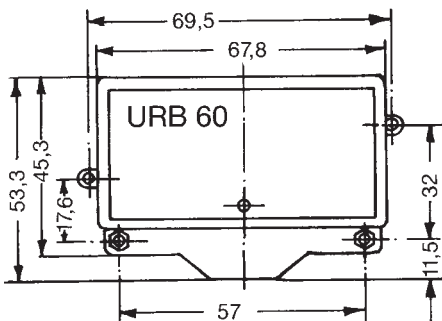
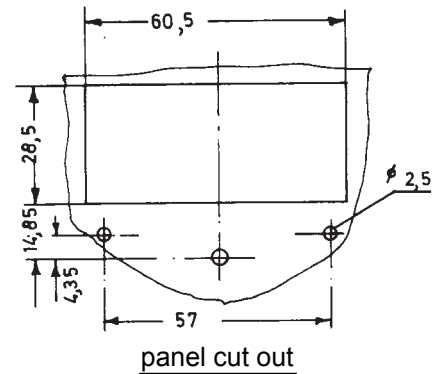
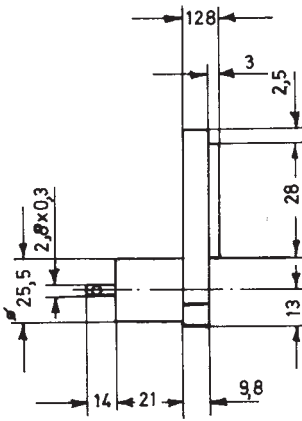
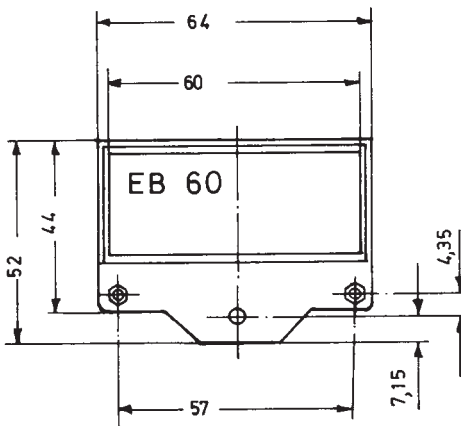
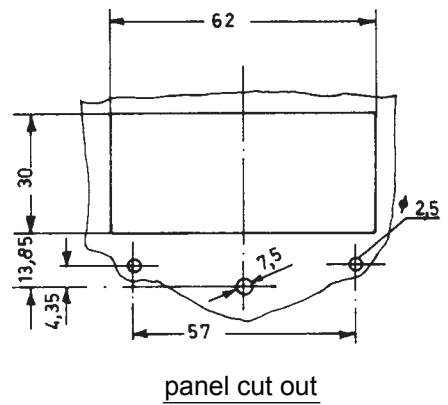
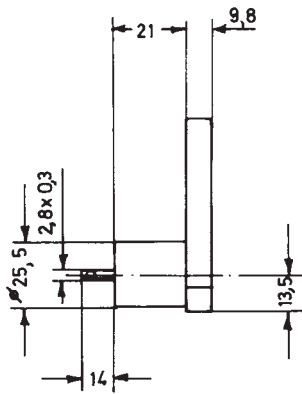
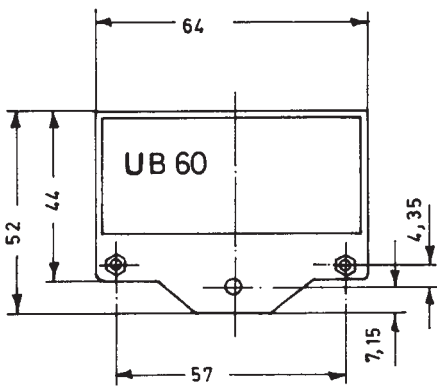
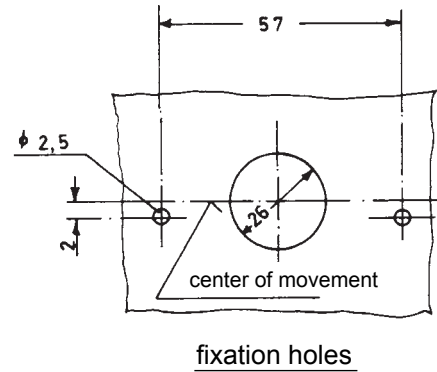
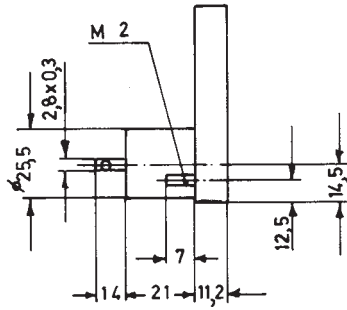
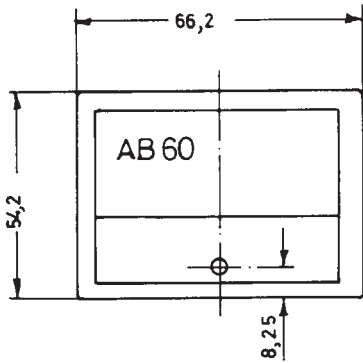

Size 75

Interserie Moving Coil Meter

90° or 105° Pointer Deflection

Available housings:

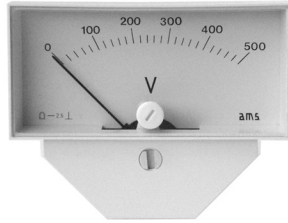

EBN 75 I-III
built-in type

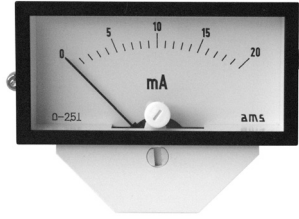

URB 75
submounting type

Movement	moving coil with core magnet
Bearing	pivots with spring mounted jewels
Pointer	tube pointer as standard; knife-edge pointer for mirror scale
Accuracy class	1.5 or 2.5 (class 1 on request)
Scale	interchangeable slide-in scale (also available with mirror scale) if fsd 90° scale length approx. 53 mm if fsd 105° scale length approx. 61 mm
URB frame colour	black; light grey or dark grey on demand

Measuring range	Ammeters	Internal resistance	Voltmeters	Internal resistance
	100 µA	4000 Ω	100 mV	} 1000 Ω/V
	150 µA	4000 Ω	150 mV	
	250 µA	1300 Ω	400 mV	
	400 µA	1100 Ω	600 mV	
	600 µA	380 Ω	1 V	
	1 mA	70 Ω	1.5 V	
	1.5 mA	30 Ω	2.5 V	
	2.5 mA	13 Ω	4 V	
	4 mA	11 Ω	6 V	
	6 mA	5.5 Ω	10 V	
	10 mA	3 Ω	15 V	
	15 mA	2.8 Ω	25 V	
	20 mA	2.3 Ω	40 V	
	25-600 mA	60 mV	60 V	
	1 A •	60 mV	100 V	
	1.5 A •	60 mV	150 V	
	2.5 A •	60 mV	250 V	
	4 A •	60 mV	400 V	
	60 mV x	12 Ω		
	150 mV x	58 Ω		

• Shunt fitted on the rear
x For operation with separate shunt
Tolerance of the Internal resistance ± 20%

Ammeters for direct connection of up to 40 A in housings ... 75 DE

Size 75 Moving Coil Meter

"INTERSERIE" METERS

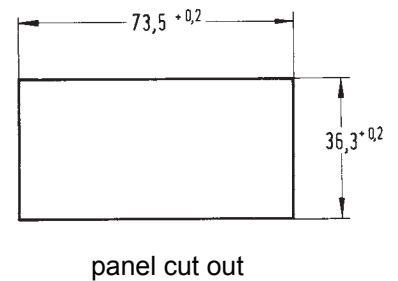
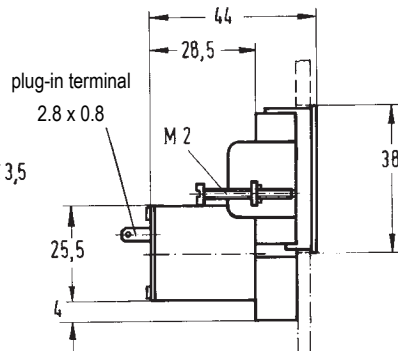
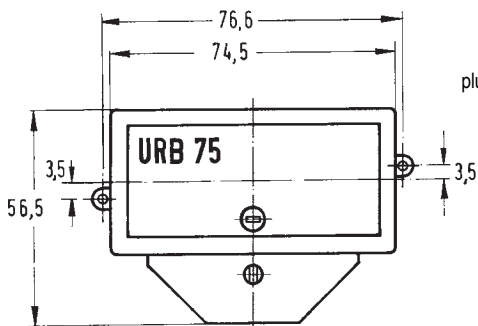
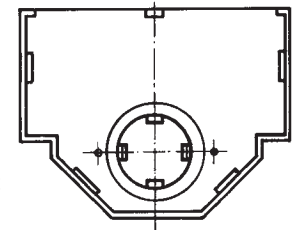
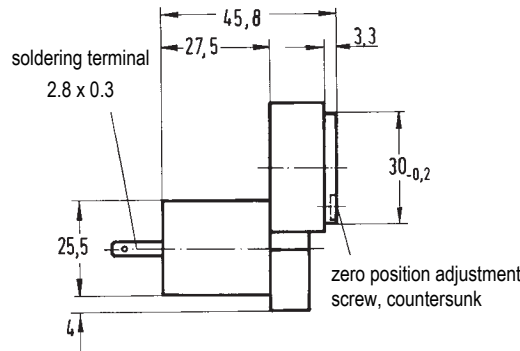
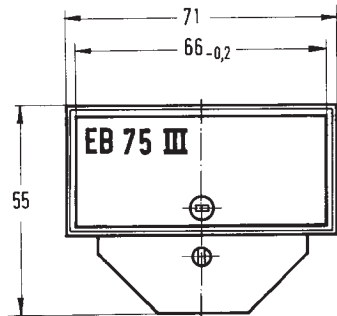
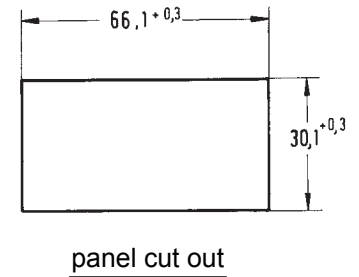
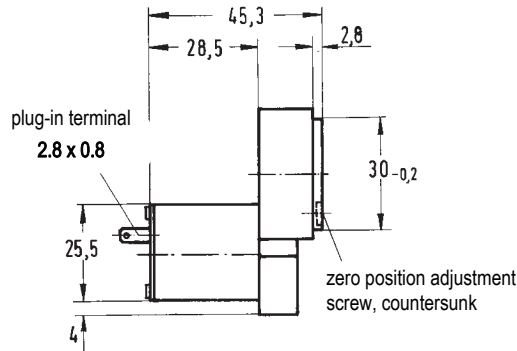
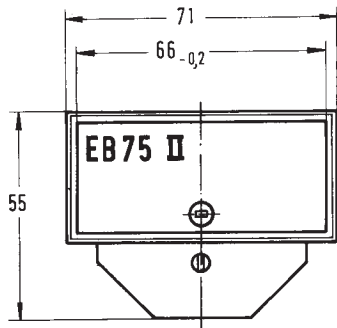
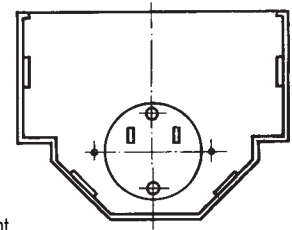
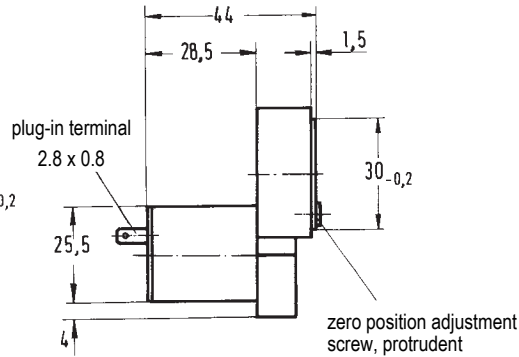
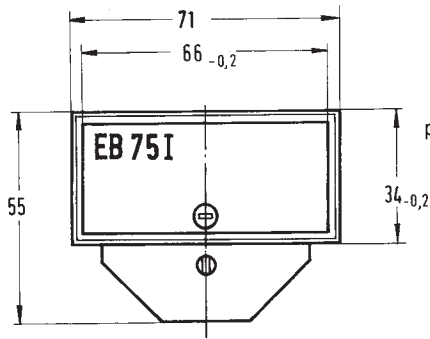

Size 80

Interserie Moving Coil Meter

90° or 105° Pointer Deflection

Available housings:

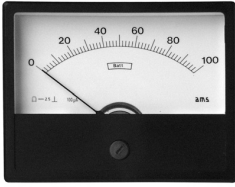

AB 80

panel mounting type

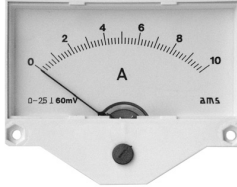

UB 80

submounting type

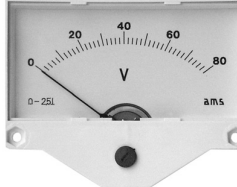

EB 80

built-in type

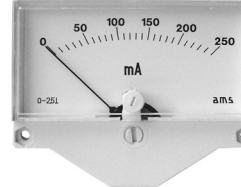

EBN 80

built-in type

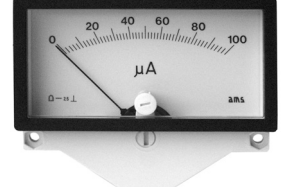

URB 80

with submounting frame

Movement	moving coil with core magnet
Bearing	pivots with spring mounted jewels
Pointer	tube pointer as standard; knife-edge pointer for mirror scale
Accuracy class	1.5 or 2.5 (class 1 on request)
Scale	interchangeable slide-in scale (also available with mirror scale) if fsd 90° scale length approx. 55 mm if fsd 105° scale length approx. 62 mm
Front frame colour	dark grey similar to RAL 7011; light grey or black on demand
URB frame colour	black

Measuring range	Ammeters	Internal resistance	Voltmeters	Internal resistance
	100 µA	4000 Ω	100 mV	} 1000 Ω/V
	150 µA	4000 Ω	150 mV	
	250 µA	1300 Ω	400 mV	
	400 µA	1100 Ω	600 mV	
	600 µA	380 Ω	1 V	
	1 mA	70 Ω	1.5 V	
	1.5 mA	30 Ω	2.5 V	
	2.5 mA	13 Ω	4 V	
	4 mA	11 Ω	6 V	
	6 mA	5.5 Ω	10 V	
	10 mA	3 Ω	15 V	
	15 mA	2.8 Ω	25 V	
	20 mA	2.3 Ω	40 V	
	25-600 mA	60 mV	60 V	
	1 A •	60 mV	100 V	
	1.5 A •	60 mV	150 V	
	2.5 A •	60 mV	250 V	
	4 A •	60 mV	400 V	
	6 A •	60 mV	500 V	
	10 A •	60 mV	600 V	
	15 A •	60 mV		
	60 mV x	12 Ω		

• Shunt fitted on the rear
x For operation with separate shunt
Tolerance of the internal resistance ± 20%

Ammeters for direct connection of up to 40 A in housings ... 80 DE

Size 80 Moving Coil Meter

"INTERSERIE" METERS

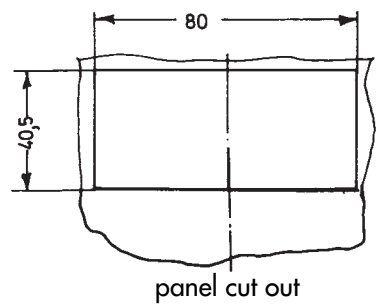
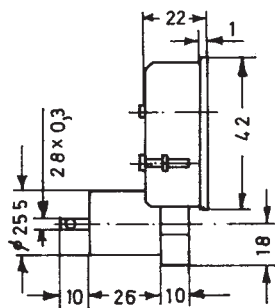
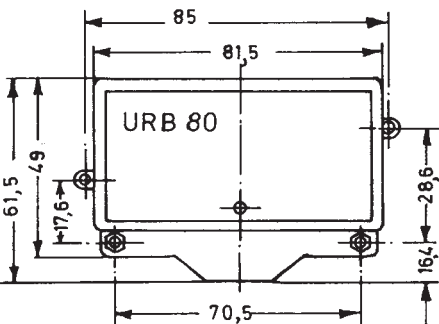
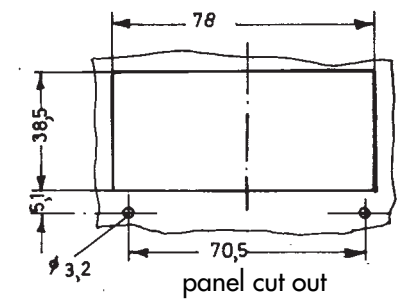
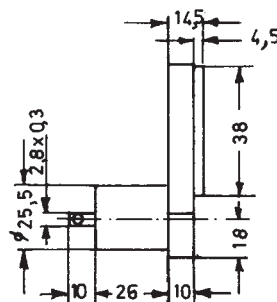
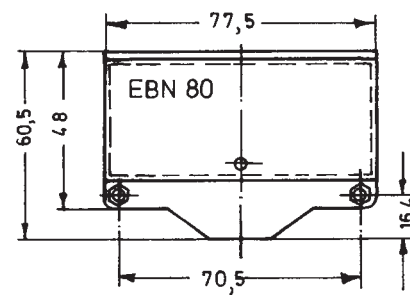
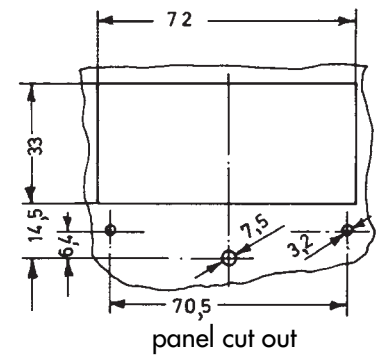
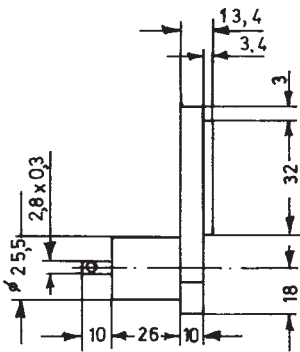
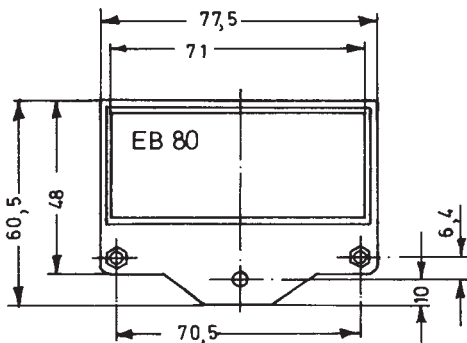
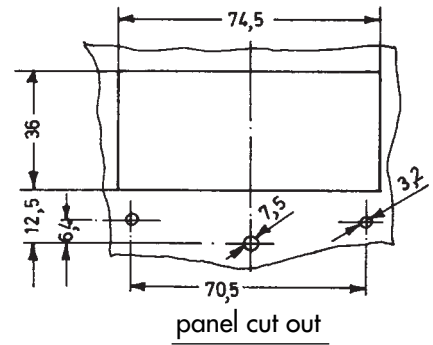
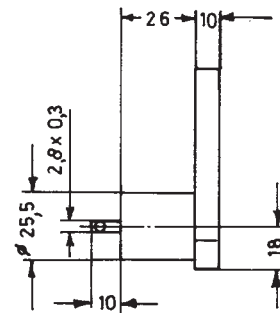
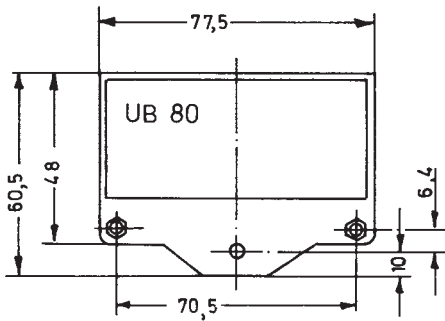
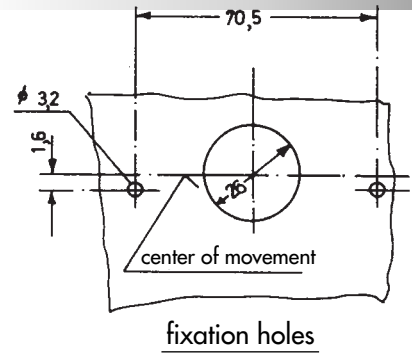
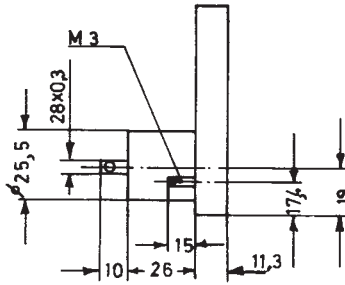
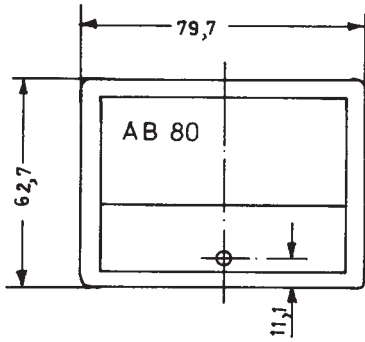

panel thickness 12 mm max.

Size 96

Interserie Moving Coil Meter

90° or 105° Pointer Deflection

Available housings:

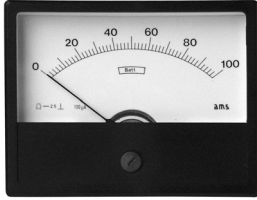

AB 96
panel mounting type

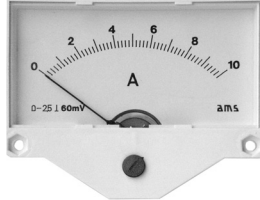

UB 96
submounting type

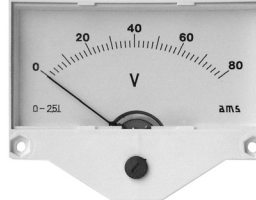

EB 96
built-in type

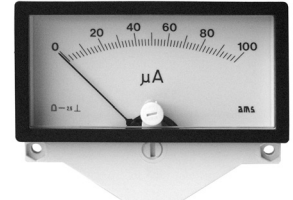

URB 96
with submounting frame

Movement	moving coil with core magnet
Bearing	pivots with spring mounted jewels
Pointer	tube pointer
Accuracy class	1.5 or 2.5
Scale	interchangeable slide-in scale if fsd 90° scale length approx. 80 mm if fsd 105° scale length approx. 87 mm
Front frame colour	dark grey similar to RAL 7011; light grey or black on demand
URB frame colour	black

Measuring range	Ammeters	Internal resistance	Voltmeters	Internal resistance
	100 µA	4000 Ω	100 mV	} 1000 Ω/V
	150 µA	4000 Ω	150 mV	
	250 µA	1300 Ω	400 mV	
	400 µA	1100 Ω	600 mV	
	600 µA	380 Ω	1 V	
	1 mA	70 Ω	1.5 V	
	1.5 mA	30 Ω	2.5 V	
	2.5 mA	13 Ω	4 V	
	4 mA	11 Ω	6 V	
	6 mA	5.5 Ω	10 V	
	10 mA	3 Ω	15 V	
	15 mA	2.8 Ω	25 V	
	20 mA	2.3 Ω	40 V	
	25-60 mA	60 mV	60 V	
	1 A [•]	60 mV	100 V	
	1.5 A [•]	60 mV	150 V	
	2.5 A [•]	60 mV	250 V	
	4 A [•]	60 mV	400 V	
	6 A [•]	60 mV	500 V	
	10 A [•]	60 mV	600 V	
	15 A [•]	60 mV		
	60 mV ^x	12 Ω		

• Shunt fitted on the rear
x For operation with separate shunt
Tolerance of the internal resistance ± 20%

Ammeters for direct connection of up to 40 A in housings ... 96 DE

Size 96

Moving Coil Meter

"INTERSERIE" METERS

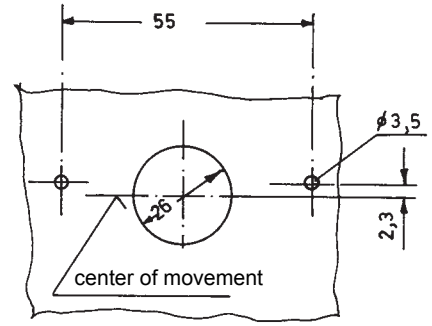
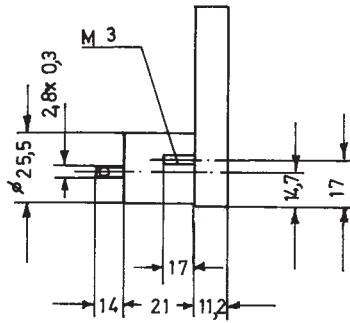
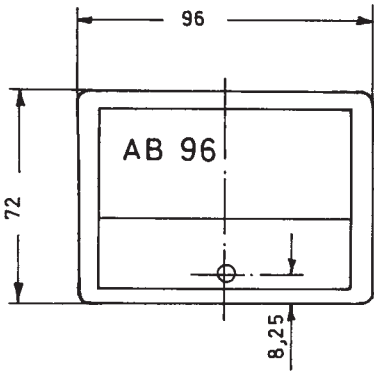

fixation holes

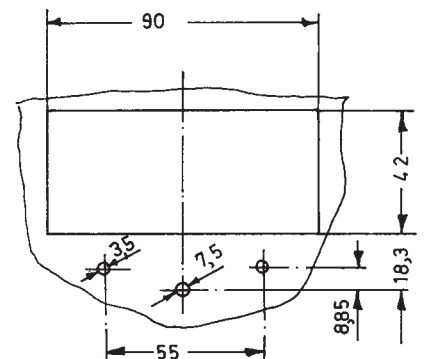
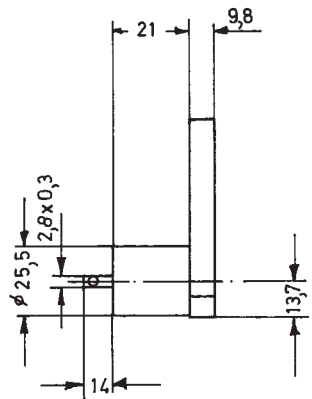
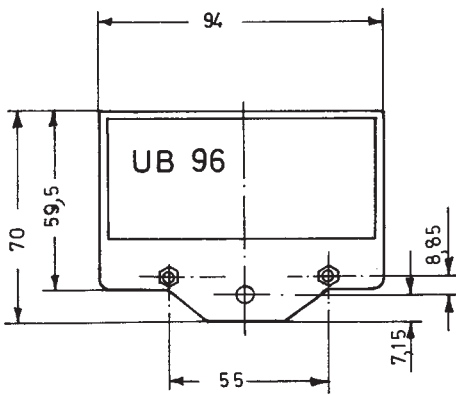

panel cut out

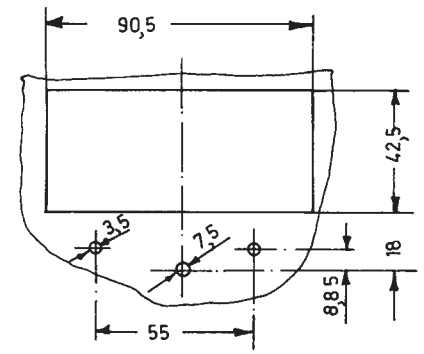
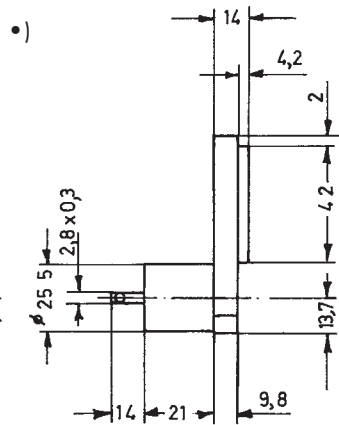
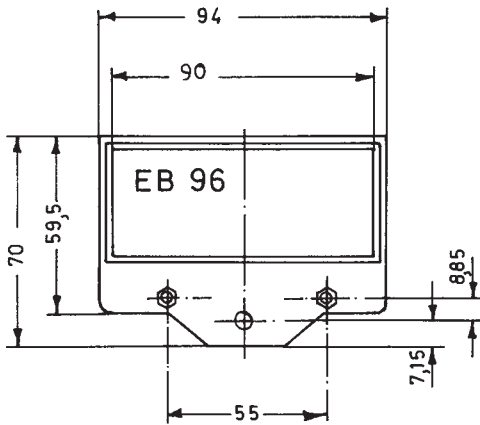

panel cut out

•) glass also available 2.8 mm thick

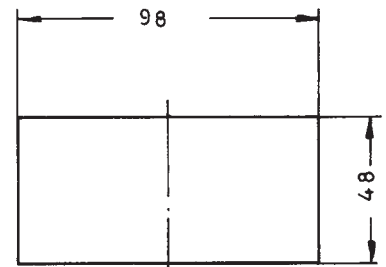
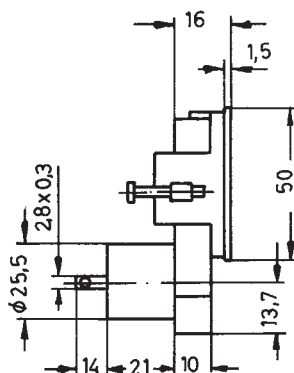
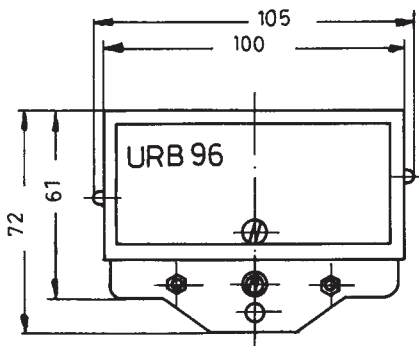

panel cut out

Size 100

Interserie Moving Coil Meter

90° or 105° Pointer Deflection

Available housings:

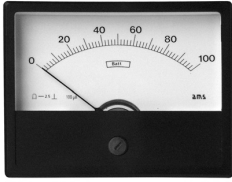

AB 100
panel mounting type

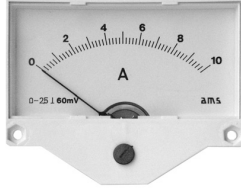

UB 100
submounting type

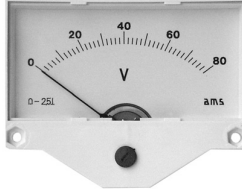

EB 100
built-in type

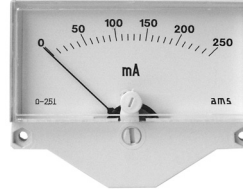

EBN 100
built-in type

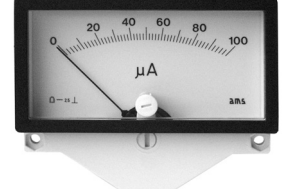

URB 100
with submounting frame

Movement	moving coil with core magnet
Bearing	pivots with spring mounted jewels
Pointer	tube pointer as standard; knife-edge pointer for mirror scale
Accuracy class	1.5 or 2.5 (class 1 on request)
Scale	interchangeable slide-in scale (also available with mirror scale) if fsd 90° scale length approx. 83 mm if fsd 105° scale length approx. 90 mm
Front frame colour	dark grey similar to RAL 7011; light grey or black on demand
URB frame colour	black

Measuring range	Ammeters	Internal resistance	Voltmeters	Internal resistance
	100 µA	4000 Ω	100 mV	} 1000 Ω/V
	150 µA	4000 Ω	150 mV	
	250 µA	1300 Ω	400 mV	
	400 µA	1100 Ω	600 mV	
	600 µA	380 Ω	1 V	
	1 mA	70 Ω	1.5 V	
	1.5 mA	30 Ω	2.5 V	
	2.5 mA	13 Ω	4 V	
	4 mA	11 Ω	6 V	
	6 mA	5.5 Ω	10 V	
	10 mA	3 Ω	15 V	
	15 mA	2.8 Ω	25 V	
	20 mA	2.3 Ω	40 V	
	25-600 mA	60 mV	60 V	
	1 A •	60 mV	100 V	
	1.5 A •	60 mV	150 V	
	2.5 A •	60 mV	250 V	
	4 A •	60 mV	400 V	
	6 A •	60 mV	500 V	
	10 A •	60 mV	600 V	
	15 A •	60 mV		
	60 mV x	12 Ω		

• Shunt fitted on the rear
x For operation with separate shunt
Tolerance of the internal resistance ± 20%

Size 100 Moving Coil Meter

"INTERSERIE" METERS

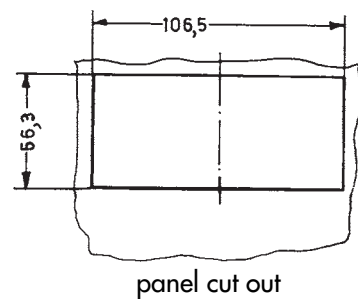
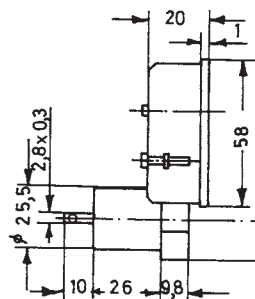
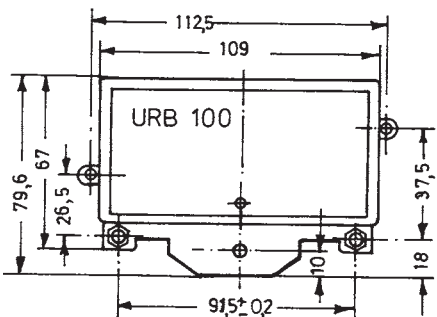
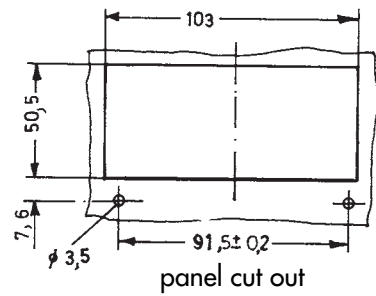
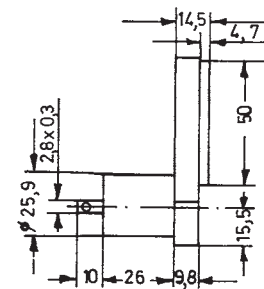
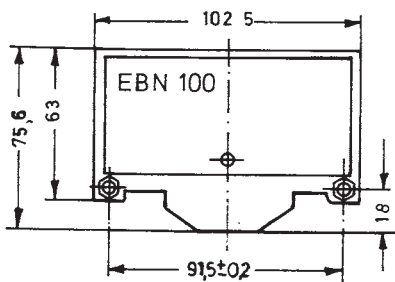
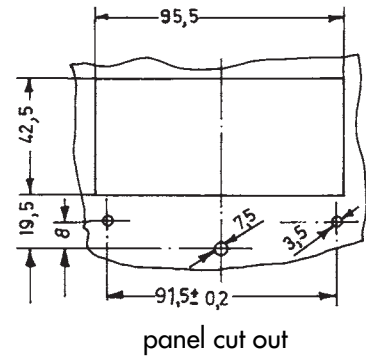
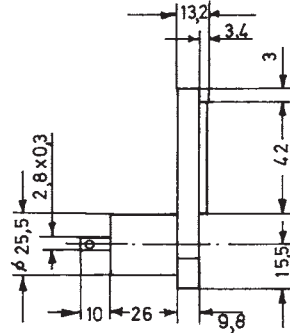
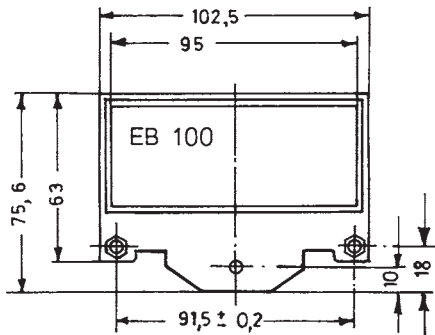
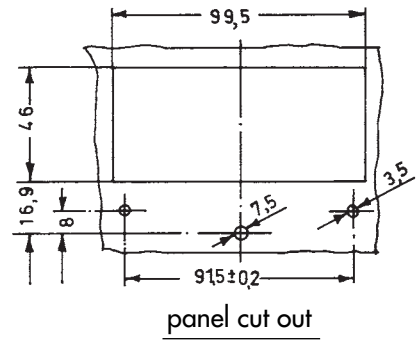
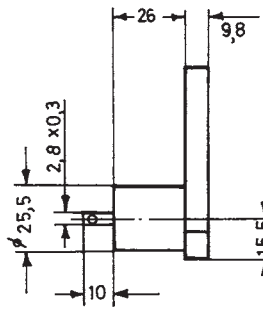
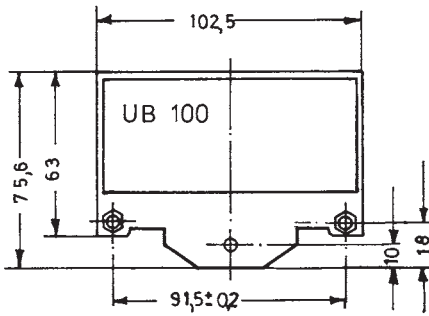
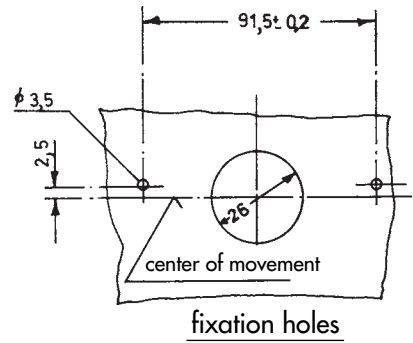
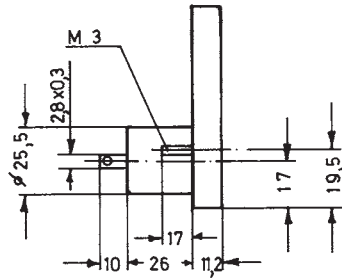
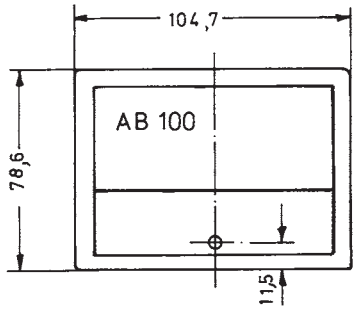

panel thickness 12 mm max.

Size 130

Interserie Moving Coil Meter

90° or 105° Pointer Deflection

Available housings:

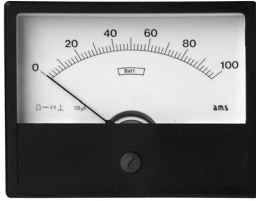

AB 130
panel mounting type

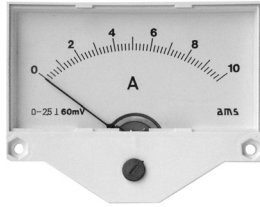

UB 130
submounting type

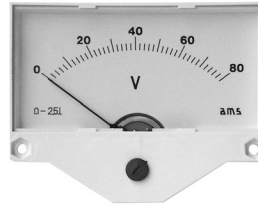

EB 130
built-in type

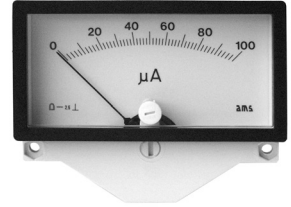

URB 130
with submounting frame

Movement	moving coil with core magnet
Bearing	pivots with spring mounted jewels
Pointer	tube pointer
Accuracy class	1.5 or 2.5 (class 1 on request)
Scale	interchangeable slide-in scale if fsd 90° scale length approx. 96 mm if fsd 105° scale length approx. 115 mm
Front frame colour	dark grey similar to RAL 7011; light grey or black on demand
URB frame colour	black

Measuring range	Ammeters	Internal resistance	Voltmeters	Internal resistance
	100 µA	6300 Ω	100 mV	} 1000 Ω/V
	150 µA	6300 Ω	150 mV	
	250 µA	2600 Ω	400 mV	
	400 µA	1300 Ω	600 mV	
	600 µA	380 Ω	1 V	
	1 mA	85 Ω	1.5 V	
	1.5 mA	47 Ω	2.5 V	
	2.5 mA	16 Ω	4 V	
	4 mA	10 Ω	6 V	
	6 mA	5.5 Ω	10 V	
	10 mA	3 Ω	15 V	
	15 mA	2.8 Ω	25 V	
	20 mA	2.3 Ω	40 V	
	25-600 mA	60 mV	60 V	
	1 A [•]	60 mV	100 V	
	1.5 A [•]	60 mV	150 V	
	2.5 A [•]	60 mV	250 V	
	4 A [•]	60 mV	400 V	
	6 A [•]	60 mV	500 V	
	10 A [•]	60 mV	600 V	
	15 A [•]	60 mV		
	60 mV x	12 Ω		

• Shunts fitted to the rear
x For operation with separate shunt
Tolerance of the internal resistance ± 20%

Size 130 Moving Coil Meter

"INTERSERIE" METERS

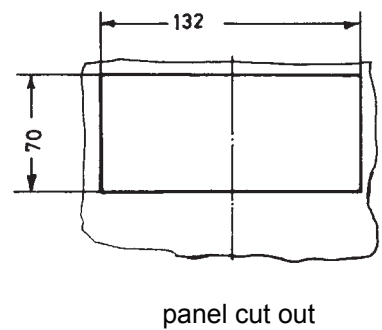
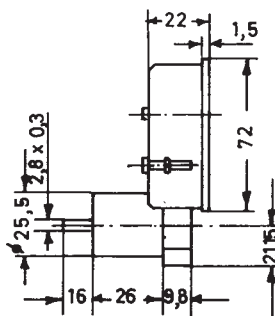
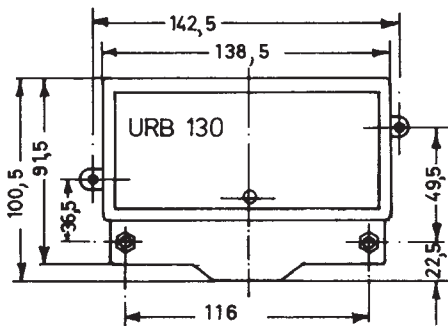
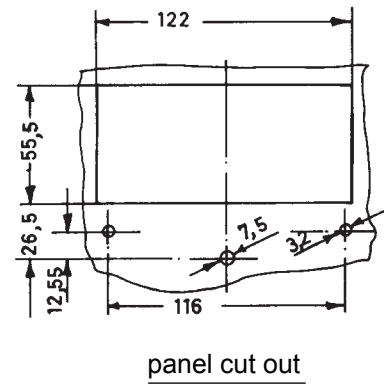
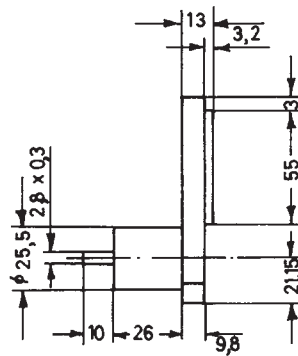
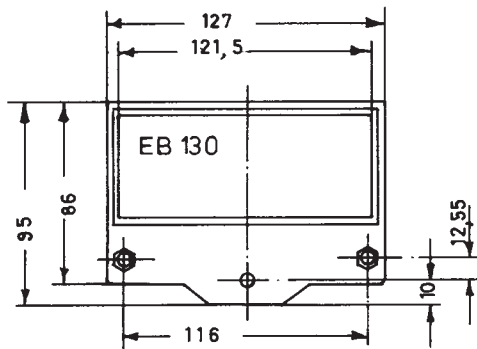
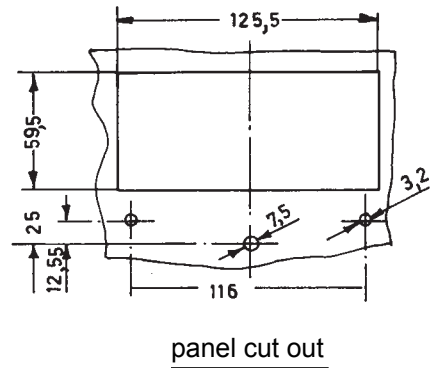
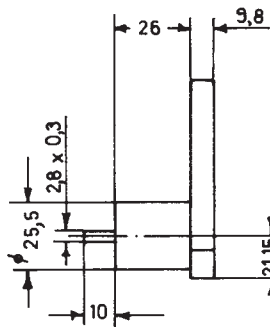
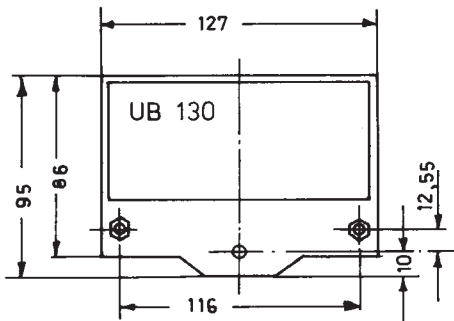
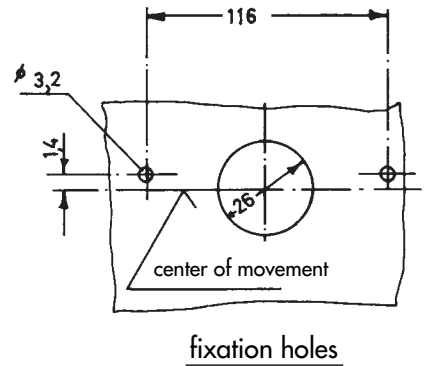
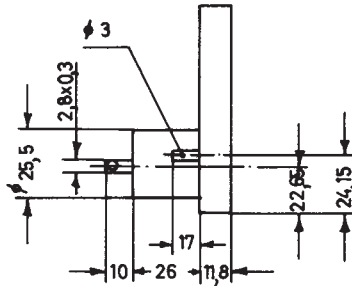
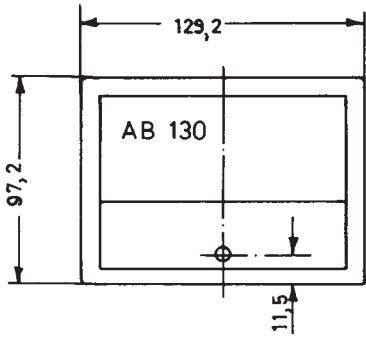

panel thickness 12.5 mm max.

Special Designs

"Interserie" Moving Coil Meters

Housings

Front frame colour

type AB: standard dark grey
black or light grey on request
type URB: standard black
light grey on request

Zero position screw inside movement tube

sizes 60, 80, 96 and 100

Shortened movement tube

for ammeters, measuring ranges from 100 μ A to 20 mA
tube length approx. 16 mm for sizes 60, 80, 96 and 100

Hole for diode Temperature resistant Illumination

in housing base part and scale
up to +100 °C for all types
all sizes available with translucent housing base and translucent scale
for external illumination
sizes 60, 80 and 100 can be equipped with an illumination tube on the
back of the housing

Scales

Mirror scale Colored scales

for sizes 55, 60, 80, 96, 100 and 130 combined with knife-edge pointer
scale background black, scale division and numbering white or yellow
other colours on request

Scale divisions

coloured scale divisions or marks
double or multiple divisions
calibration according to curve or table

Movements

Internal resistance voltmeter

standard approx. 1000 Ω /V
special versions: 2000 Ω /V
5000 Ω /V
10,000 Ω /V
20,000 Ω /V possible only to a limited extend

Initial range stretched

approximately 25% of the end value at the centre of the scale division

Rectifier (for measuring AC)

voltmeters from 6 to 250 V: built-in rectifier
from 250 V: external rectifier

ammeters up to 20 mA: built-in rectifier
from 1 to 25 A: with separate current transformer n/0.01 A

Mechanical zero position

centre or on side (within the scale division)

Ammeters for direct connection

up to 40 A for sizes 60, 75, 80 and 96
however, in the housing tube for moving iron

The Moving Iron Instruments of the "Interserie"

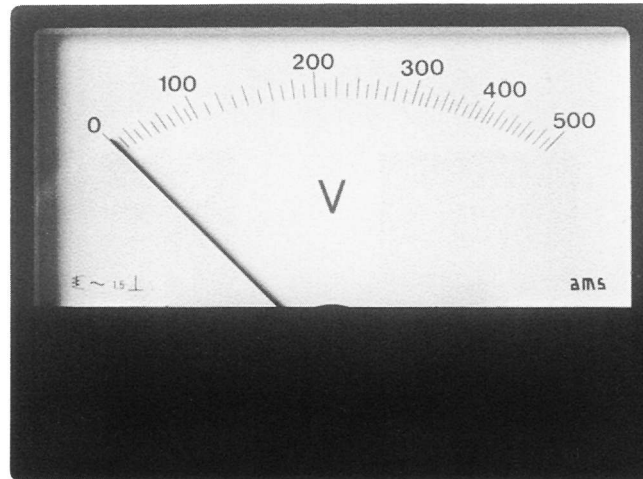

- utilize pivot, spring and jewel movements with magnetic shielding.
- are available in 4 different housing sizes for up to 5 built-in variations.
- have interchangeable slide-in scales by default.
- are available with translucent scale (for external illumination) or with built-in illumination tube.
- have a pointer deflection of 90°.
- are available with accuracy class 1.5 or 2.5.

Size 60

Interserie Moving Iron Meter with interchangeable scale

Available housings:

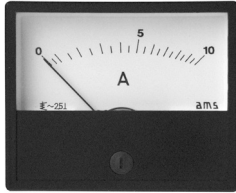

AB 60 DE

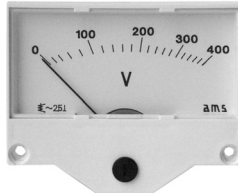

UB 60 DE

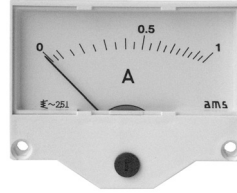

EB 60 DE

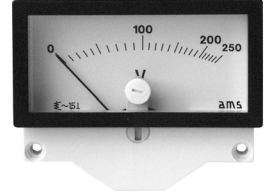

URB 60 DE

Movement

**Bearing
Pointer**

Accuracy class

Scale length

Front frame colour

moving iron, silicone damped
and screened against magnetic fields
pivots with spring mounted jewel
tube pointer
1.5 or 2.5
approx. 48 mm
dark grey, similar to RAL 7011
on demand lightgrey or black

Measuring ranges

Ammeters

100 / 200 mA
150 / 300 mA
250 / 500 mA
400 / 800 mA
600 / 1200 mA
1 / 2 A
1.5 / 3 A
2.5 / 5 A
4 / 8 A
6 / 12 A
10 / 20 A
15 / 30 A
25 / 50 A

Voltmeters

10 V
15 V
25 V
30 V
40 V
60 V
100 V
150 V
250 V
300 V
400 V
500 V

for connection to separate
current transformer

sec. 1 / 2 A
or 5 / 10 A

for connection to separate
voltage transformer

sec. 100 V
or 110 V

Ammeters also available without overload scaling

Size 60 Moving Iron Meter

"INTERSERIE" METERS

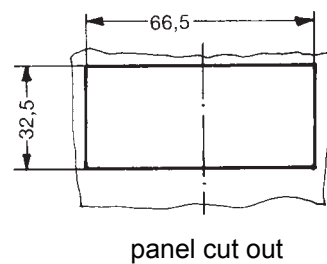
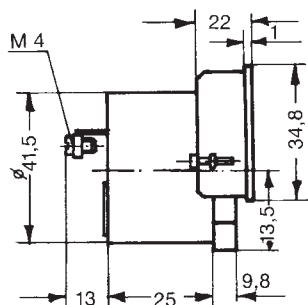
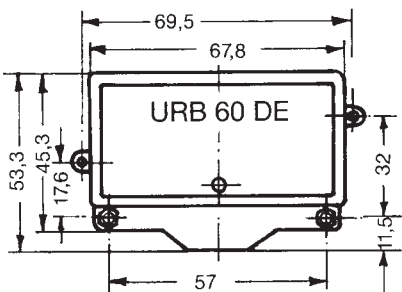
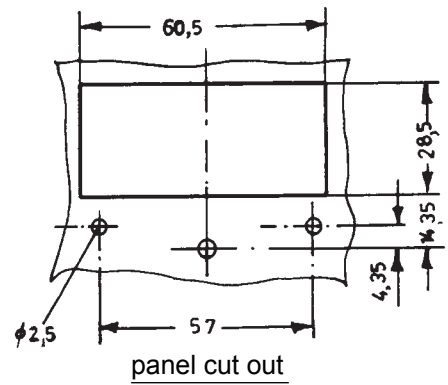
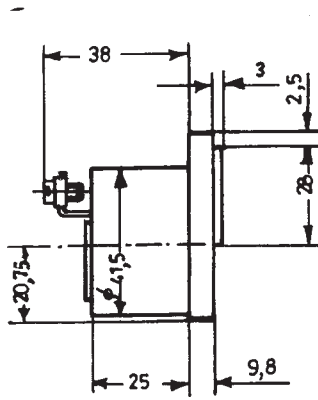
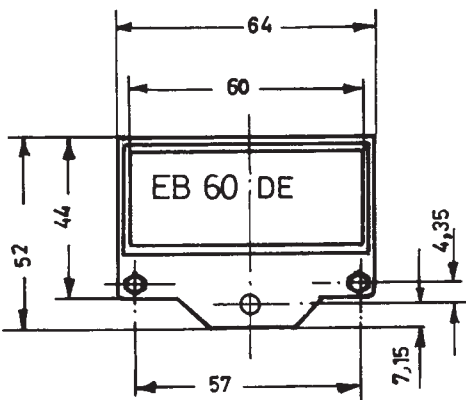
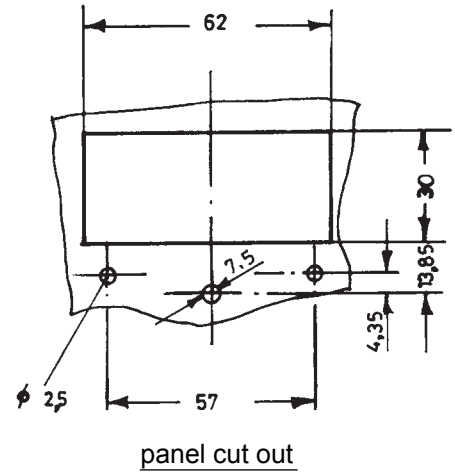
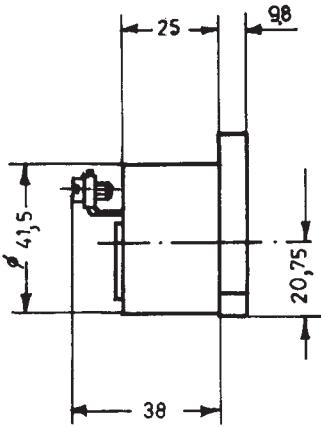
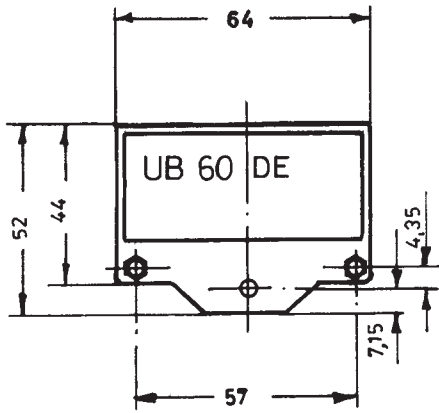
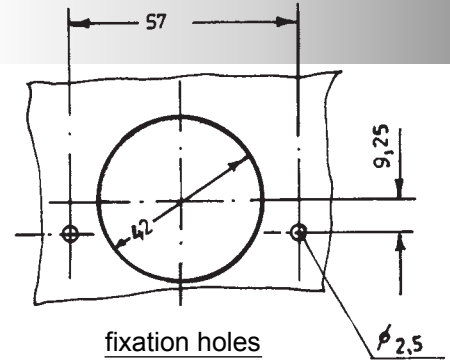
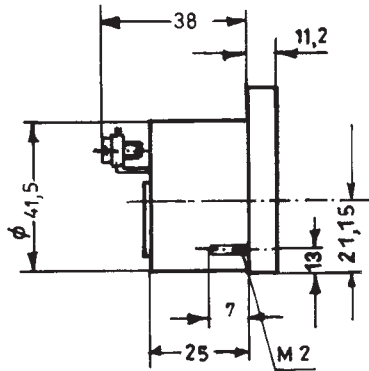
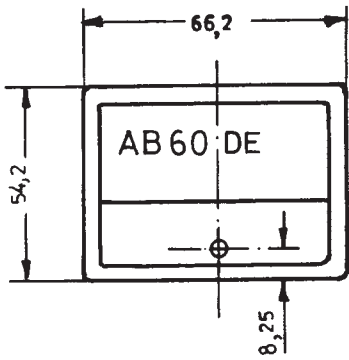

Size 75

Interserie Moving Iron Meter with interchangeable scale

Available housings:

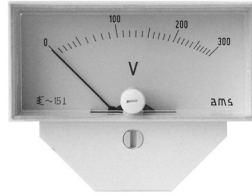

EB 75 DE I - III
built-in type

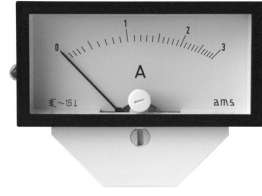

URB 75 DE
submounting type

Movement

Bearing

Pointer

Accuracy class

Scale length

URB-frame

moving iron, silicone damped
and screened against magnetic fields
pivots with spring mounted jewel
tube pointer or beam-type knife-edge pointer
1.5 or 2.5
approx. 53 mm
black
on demand lightgrey or black

Measuring ranges

Ammeters

100 / 200 mA
150 / 300 mA
250 / 500 mA
400 / 800 mA
600 / 1200 mA
1 / 2 A
1.5 / 3 A
2.5 / 5 A
4 / 8 A
6 / 12 A
10 / 20 A
15 / 30 A
25 / 50 A
40 / 80 A

Voltmeters

10 V
15 V
25 V
30 V
40 V
60 V
100 V
150 V
250 V
300 V
400 V
500 V
600 V

for connection to separate
current transformer

sec. 1 / 2 A
or 5 / 10 A

for connection to separate
voltage transformer

sec. 100 V
or 110 V

Ammeters also available without overload scaling

Size 75 Moving Iron Meter

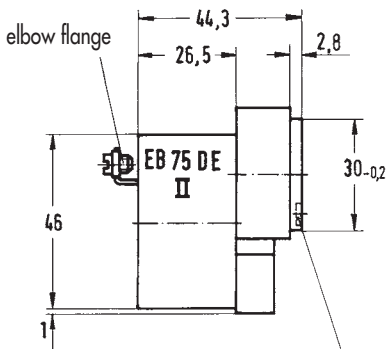
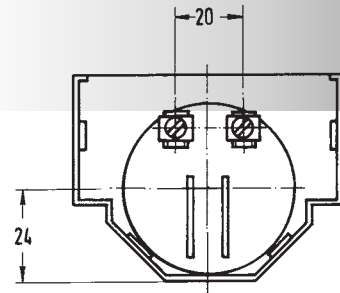
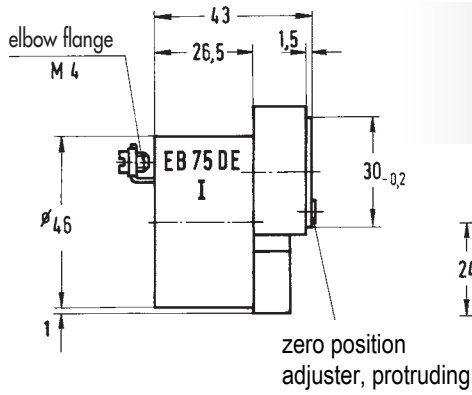
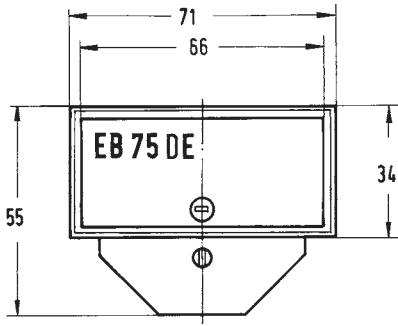

zero position adjuster, countersunk

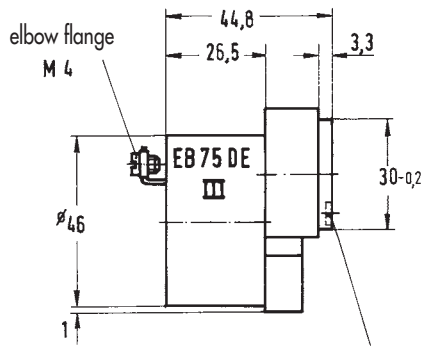

zero position adjuster, countersunk

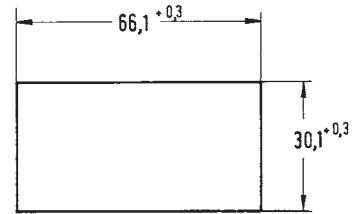

panel cut out

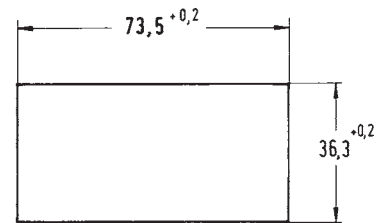
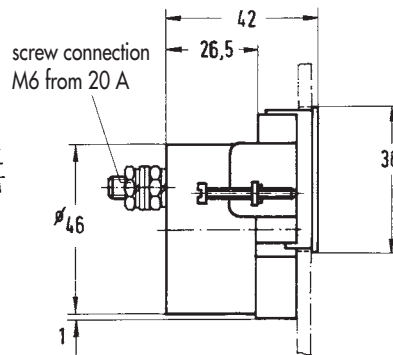
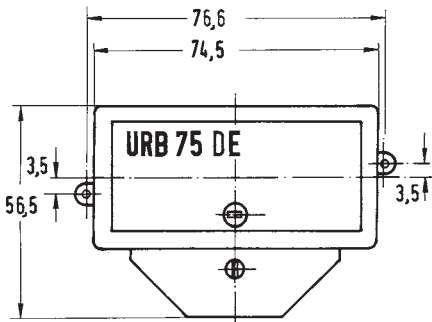

panel cut out

preresistor
moving iron voltmeter

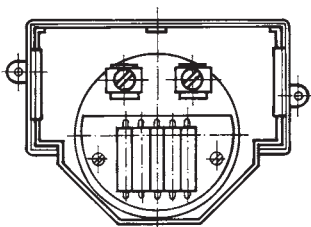

meter with two
measurement ranges

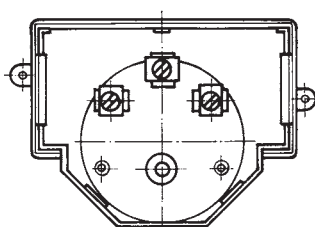

ammeter from 20 A

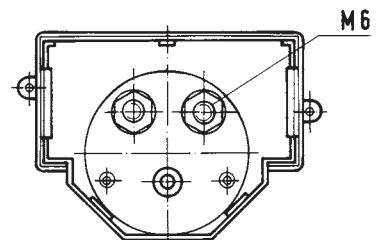

Size 80

Interserie Moving Iron Meter with interchangeable scale

Available housings:

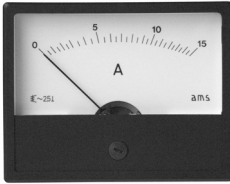

AB 80 DE

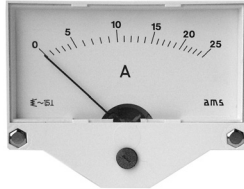

UB 80 DE

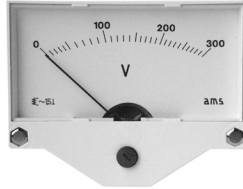

EB 80 DE

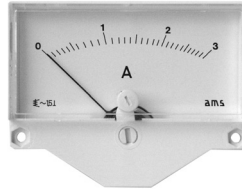

EBN 80 DE

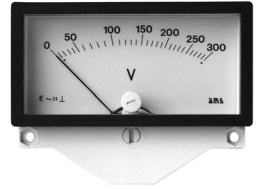

URB 80 DE

Movement	moving iron, silicone damped and screened against magnetic fields
Bearing	pivots with spring mounted jewel
Pointer	tube pointer or beam-type knife-edge pointer
Accuracy class	1.5 or 2.5
Scale length	approx. 55 mm
Front frame colour	dark grey, similar to RAL 7011 on demand lightgrey or black
URB-frame	black

Measuring ranges

Ammeters

100 / 200 mA
150 / 300 mA
250 / 500 mA
400 / 800 mA
600 / 1200 mA
1 / 2 A
1.5 / 3 A
2.5 / 5 A
4 / 8 A
6 / 12 A
10 / 20 A
15 / 30 A
25 / 50 A
40 / 80 A

for connection to separate
current transformer

sec.	1 / 2 A
or	5 / 10 A

Voltmeters

10 V
15 V
25 V
30 V
40 V
60 V
100 V
150 V
250 V
300 V
400 V
500 V
600 V

for connection to separate
current transformer

sec.	100 V
or	110 V

Ammeters also available without overload scaling

Size 96

Interserie Moving Iron Meter with interchangeable scale

Available housings:

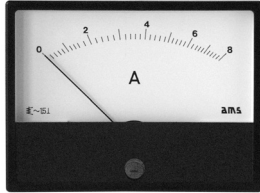

AB 96 DE

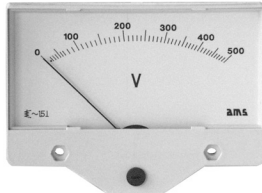

UB 96 DE

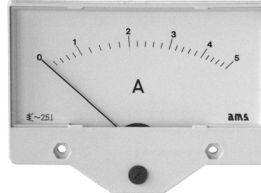

EB 96 DE

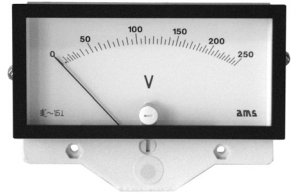

URB 96 DE

Movement

moving iron, silicone damped and screened against magnetic fields

Bearing

pivots with spring mounted jewel

Pointer

tube pointer or beam-type knife-edge pointer

Accuracy class

1.5 or 2.5

Scale length

approx. 80 mm

Front frame colour

dark grey, similar to RAL 7011

URB-Frame

on demand lightgrey or black
black

Measuring ranges

Ammeters

- 100 / 200 mA
- 150 / 300 mA
- 250 / 500 mA
- 400 / 800 mA
- 600 / 1200 mA
- 1 / 2 A
- 1.5 / 3 A
- 2.5 / 5 A
- 4 / 8 A
- 6 / 12 A
- 10 / 20 A
- 15 / 30 A
- 25 / 50 A
- 40 / 80 A

Voltmeters

- 10 V
- 15 V
- 25 V
- 30 V
- 40 V
- 60 V
- 100 V
- 150 V
- 250 V
- 300 V
- 400 V
- 500 V
- 600 V

for connection to separate current transformer

- sec. 1 / 2 A
- or 5 / 10 A

for connection to separate voltage transformer

- sec. 100 V
- or 110 V

Ammeters also available without overload scaling

Size 96 Moving Iron Meter

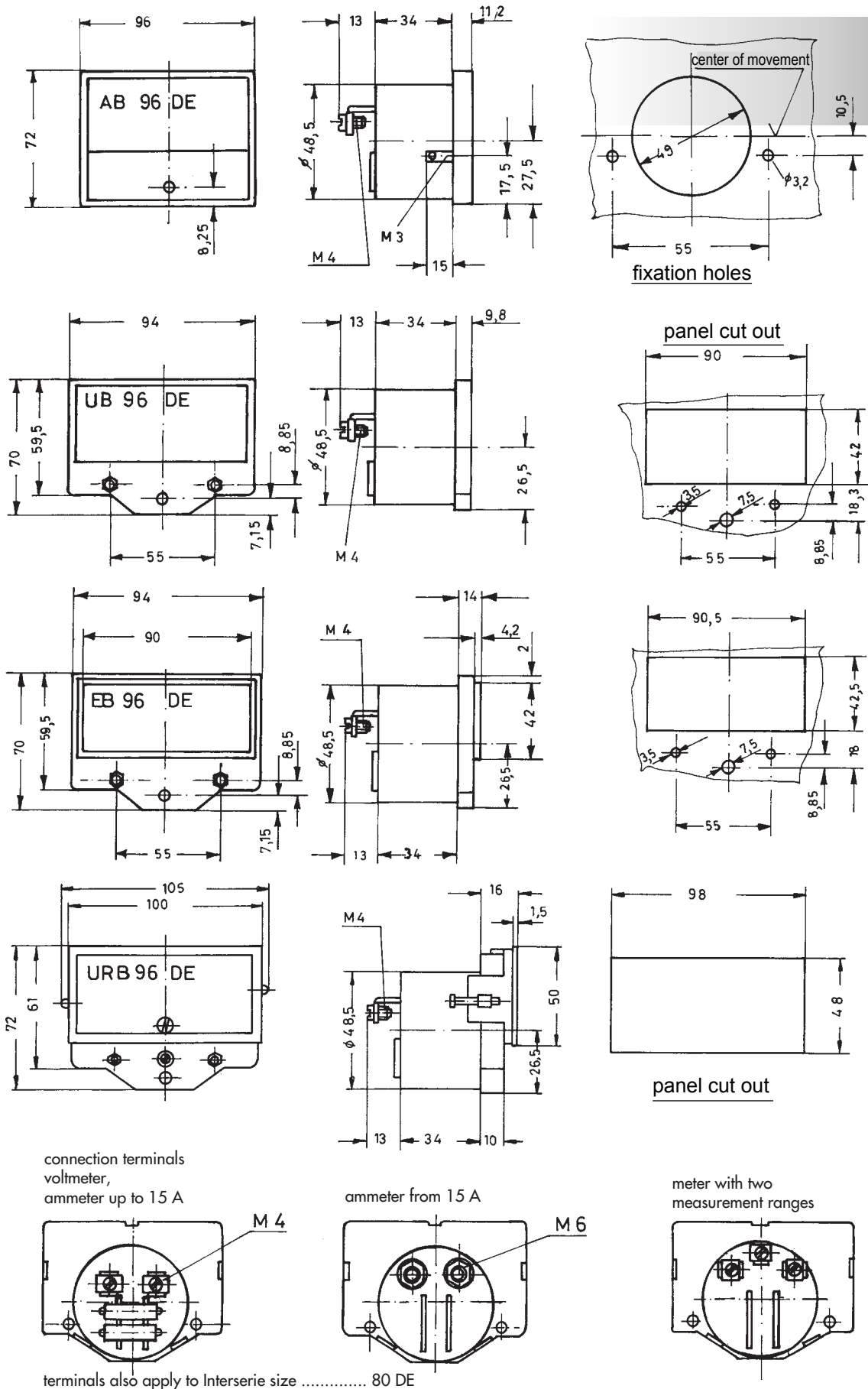

"INTERSERIE" METERS

Special Versions

Interserie Moving Iron Meters

Housing

Front frame colours

AB-version: standard: dark grey
on demand: black or light grey

URB-version: standard: black
on demand: light grey

Diodes hole

Connection terminals

in housing bottom part and scale face
tab connectors 6.3 mm for voltmeters
and ammeters up to 6 A

Scales

Mirror scale

Coloured scale

for size 60 - 80 - 96 combined with knife-edge pointer
scale background black, scale division and numbering white or yellow
other colours on request
coloured scale divisions or marks

Movements

2 measurement ranges

ammeter size 75, 80 and 96
voltmeter size 75, 80 and 96

Overload scales

size 60 - twofold (standard)
size 80 und 96 - fivefold (up to 25 A directly)

Frequency

standard $16 \frac{2}{3}$ - 100 Hz
special versions 100 - 400 Hz

Special Design Big Indicator EB 220

Big Indicator Moving Coil Meters

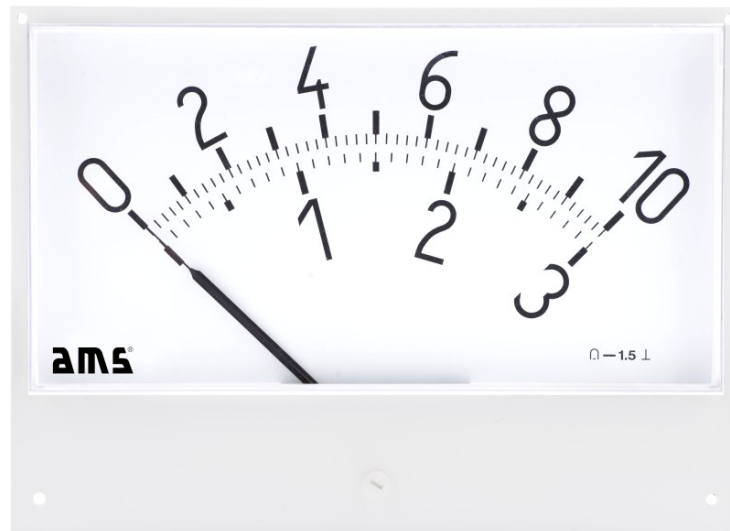

WIDE-SCALE BIG INDICATORS

- are especially developed for the didactics area - schools and training,
- have moving coil core magnet movements, immune to external electric and magnetic fields,
- are available with movements of the accuracy class 1.5 at a pointer deflection of 90°,
- are suitable for switchboard installation,
- can be integrated perfectly into custom-built switch-panels.

Special Design Big Indicator EB 220

WIDE-SCALE BIG INDICATORS

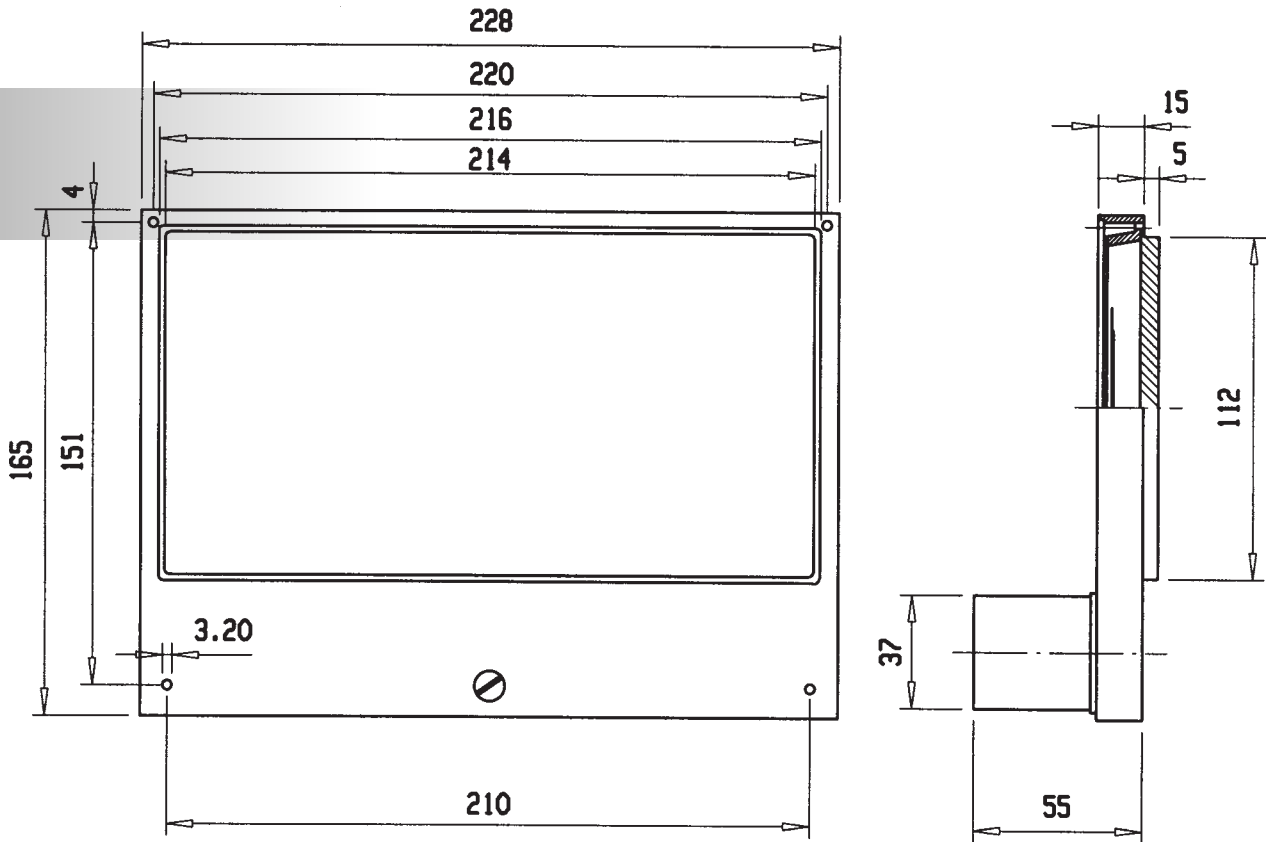

panel cut out

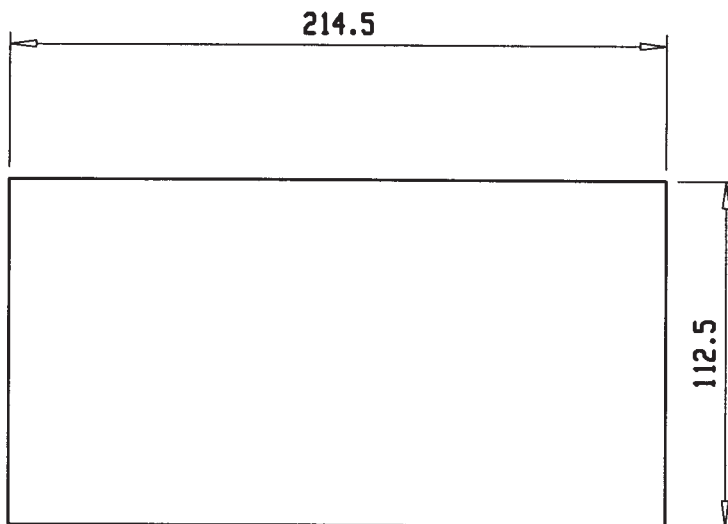

Wide-Scale Meters

Moving Coil Wide-Scale Meters

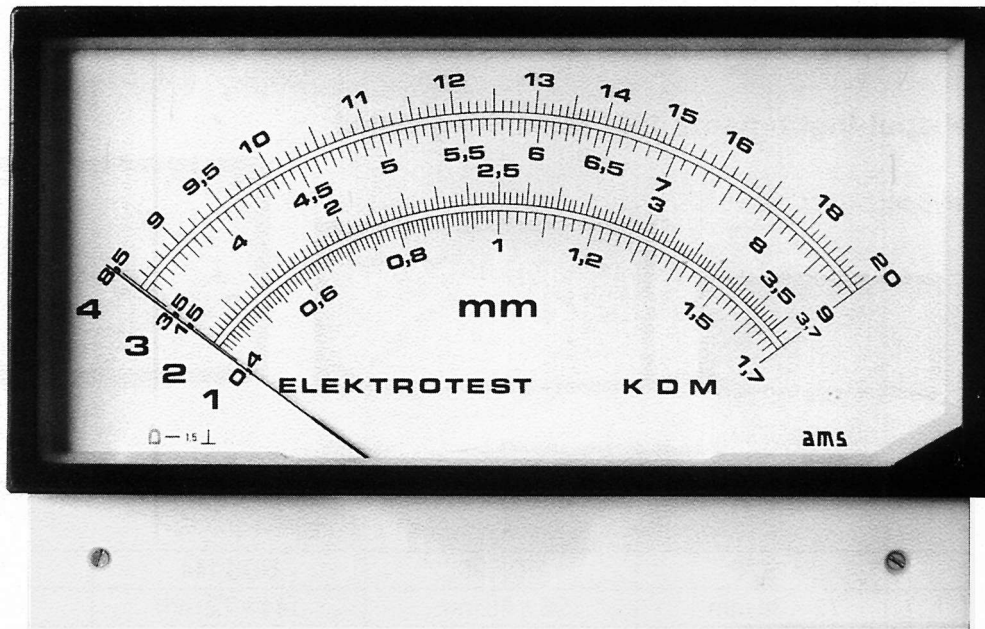

WIDE-SCALE BIG INDICATORS

- have moving coil core magnet movements, immune to external electric and magnetic fields,
- are available in two housing sizes,
- fit switchboard cut-outs according to DIN standard,
- have a pointer deflection of 105°,
- are also available with translucent housing bottom part and scale for external scale illumination.

Wide-Scale Meters

Type BDS Wide-Scale Moving Coil Meters, 105° Pointer Deflection

Available housings:

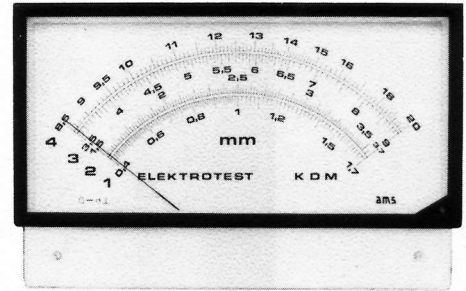
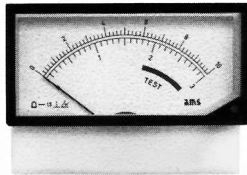

BDS 96

BDS 192

	BDS 96	BDS 192
Front frame	96 x 48 mm	192 x 96 mm
Scale length approx.	75 mm	175 mm
Weight approx.	0.14 kg	0.4 kg

Movement moving coil with core magnet
Bearing pivots with spring mounted jewels
Pointer tube pointer or tube-knife-edge pointer
Accuracy class 1.5 (class 1 on demand)
Scale on demand translucent or mirror scale
Front frame colour grey similar to RAL 7005,
 other colours on request

Measuring ranges	Ammeters		Voltmeters	
		Internal resistance/ ΔU		Internal resistance
	100 μ A	6300 Ω	100 mV	1000 Ω/V
	150 μ A	6300 Ω	150 mV	
	250 μ A	2600 Ω	400 mV	
	400 μ A	1300 Ω	600 mV	
	600 μ A	380 Ω	1 V	
	1 mA	85 Ω	1.5 V	
	1.5 mA	47 Ω	2.5 V	
	2.5 mA	16 Ω	4 V	
	4 mA	10 Ω	6 V	
	6 mA	5.5 Ω	10 V	
	10 mA	3 Ω	15 V	
	15 mA	2.8 Ω	25 V	
	20 mA	2.3 Ω	40 V	
	25 - 600 mA	60 mV		
	1 A*	60 mV		
	1.5 A*	60 mV		
	2.5 A*	60 mV		
	4 A*	60 mV		
	6 A*	60 mV		
	10 A*	60 mV		
	15 A*	60 mV		
	60 mV x)	5 Ω		

*) Shunt fitted on the rear

x) For operation with separate shunts

Tolerance of the internal resistance $\pm 20\%$

WIDE-SCALE BIG INDICATORS

Wide-Scale Meters Type BDS

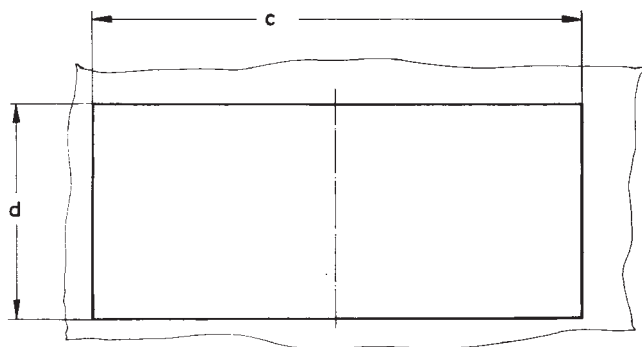
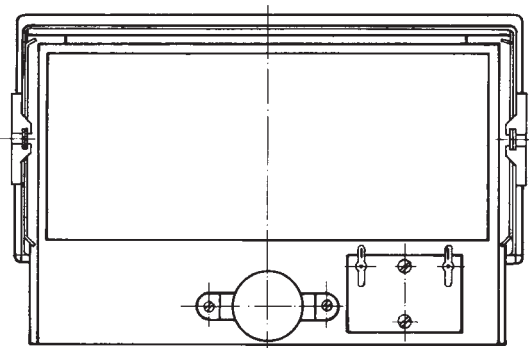
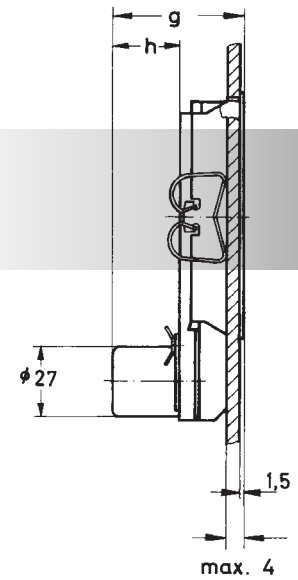
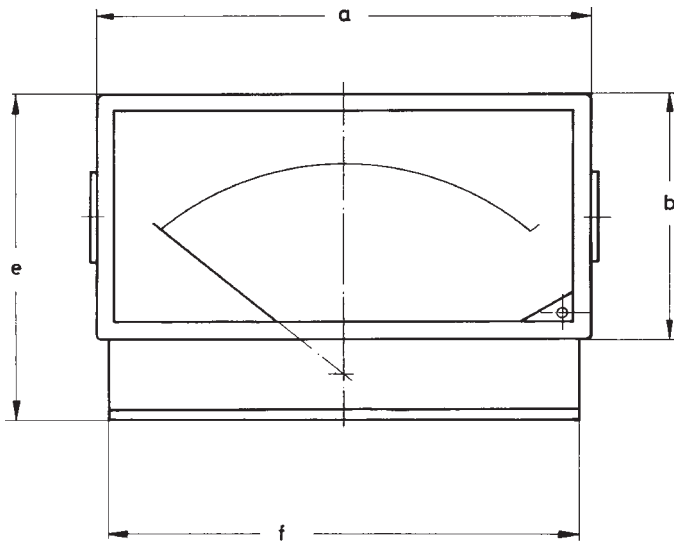

panel cut out

Dimensions for installing BDS-type meters

type	a	b	c	d	e	f	g	scale length	h
BDS 192	192	96	189	92	124	185	47	175	24,5
BDS 96	96	48	93	44	68	90	44	75	21,5

WIDE-SCALE BIG INDICATORS

Wide-Scale Meters

Special Designs

Wide-Scale Moving Coil Meters

WIDE-SCALE BIG INDICATORS

Housing

Front frame colours

standard RAL 7005 grey
other colours on request

Illumination

housing bottom part white translucent
for external illumination

Scales

Mirror scale

for sizes 96 and 192 combined with knife-edge pointer

Coloured scale

scale background black, scale division and numbering white or yellow
other colours on request
coloured scale divisions or marks
calibration in a different measurement variable

Movement

Measuring ranges

from 40 to 90 μA have a movement tube of 40 mm \varnothing (type BDS 192)

Internal resistance

Voltmeter

standard approx. 1000 Ω/V
special versions: 2000 Ω/V
5000 Ω/V
10,000 Ω/V
20,000 Ω/V possible only to a limited extend

Measurement rectifier (for measuring AC)

voltmeter 6 to 500 V, installed in housing
ammeters up to 20 mA, installed in housing
from 1 to 25 A with separate current matching transformer n/0.01 A

Square Panel Meters

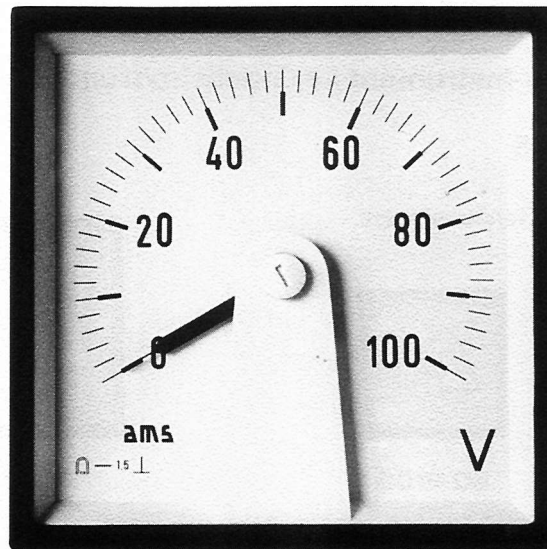
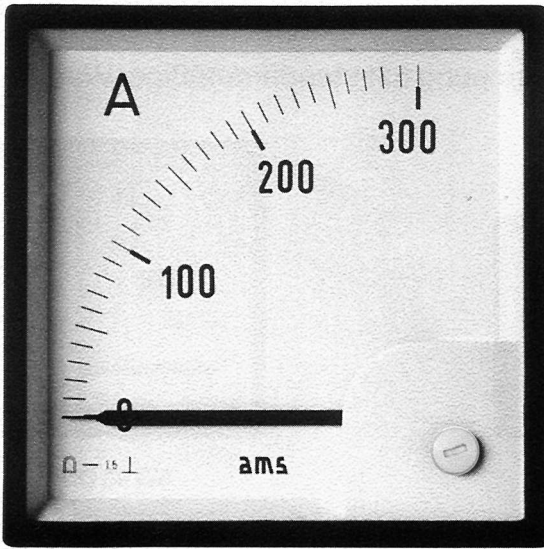

Moving coil meters

- "Ratioserie"
- Steel-sheet series

- Ratioserie in polycarbonate housing with interchangeable scale.
- Steel-sheet series with steel housing body and aluminium front frame (scale not interchangeable).
- Pointer deflection 90° or 240°.
- Ratioserie with snap-in fixing.

SQUARE MOVING COIL METERS

Square Panel Meters

"Ratioserie"

Moving Coil Meters

for direct current and direct voltage
with interchangeable scale

accuracy class 1.5

housing according to **DIN 43700**

Available housing types:

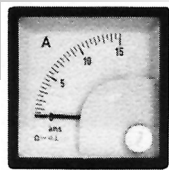

SQ 48 DS

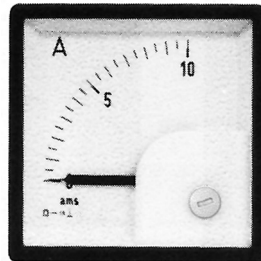

SQ 72 DS

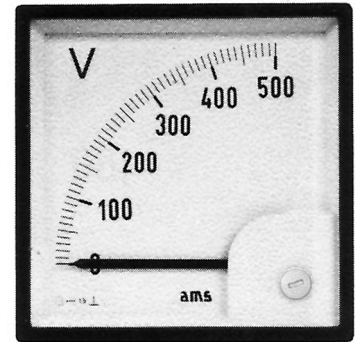

SQ 96 DS

SQUARE MOVING COIL METERS

	SQ 48 DS	SQ 72 DS	SQ 96 DS
Front frame	48 x 48 mm	72 x 72 mm	96 x 96 mm
Scale length approx.	40 mm	62 mm	97 mm
Weight approx.	0.1 kg	0.15 kg	0.2 kg

Movement

Bearing

Pointer

Housing

Front frame colour

Measuring ranges

moving coil with core magnet (immune to magnetic fields)

pivots with spring mounted jewel

beam-type knife-edge pointer

polycarbonate casing, self-extinguishing and drip-proof

black, grey on request

Ammeters

Internal resistance / ΔU

Voltmeters

Internal resistance

100 μ A

4000 Ω

100 mV

200 Ω /V

150 μ A

4000 Ω

150 mV

200 Ω /V

250 μ A

1300 Ω

400 mV

1000 Ω /V

400 μ A

1100 Ω

600 mV

1000 Ω /V

600 μ A

380 Ω

1 V

1000 Ω /V

1 mA

80 Ω

1.5 V

1000 Ω /V

1.5 mA

30 Ω

2.5 V

1000 Ω /V

2.5 mA

13 Ω

4 V

1000 Ω /V

4 mA

11 Ω

6 V

1000 Ω /V

6 mA

5.5 Ω

10 V

1000 Ω /V

10 mA

3 Ω

15 V

1000 Ω /V

15 mA

2.8 Ω

25 V

1000 Ω /V

20 mA

2.3 Ω

40 V

1000 Ω /V

25 - 600 mA

60 mV

60 V

1000 Ω /V

1 A

60 mV

100 V

1000 Ω /V

1.5 A

60 mV

150 V

1000 Ω /V

2.5 A

60 mV

250 V

1000 Ω /V

4 A

60 mV

400 V

1000 Ω /V

6 A

60 mV

500 V

1000 Ω /V

10 A

60 mV

600 V

1000 Ω /V

15 A

60 mV

Type SQ 48 DS
for direct connection
only up to 25 A

25 A

60 mV

40 A

60 mV

x) For operation with
separate shunts

60 A

60 mV

60 mV x)

12 Ω

Square Panel Meters

"Ratioserie"

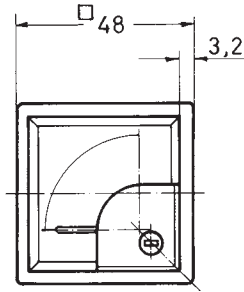

SQ 48 DS

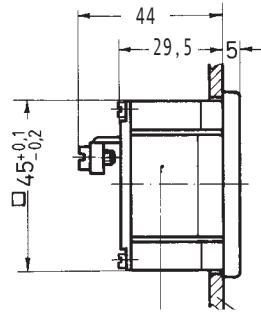

snap-in fixing for panel thickness up to 2.5 mm

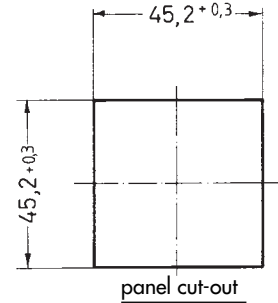

panel cut-out

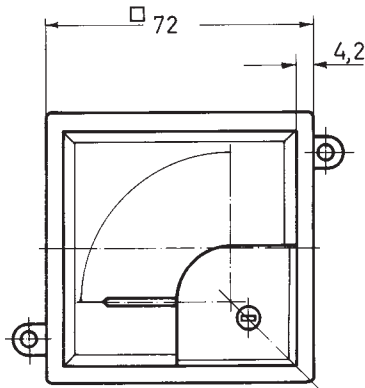

SQ 72 DS

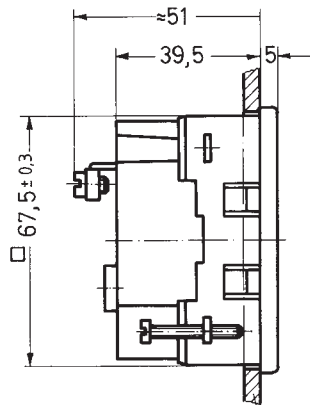

snap-in fixing for panel thickness up to 2.5 mm

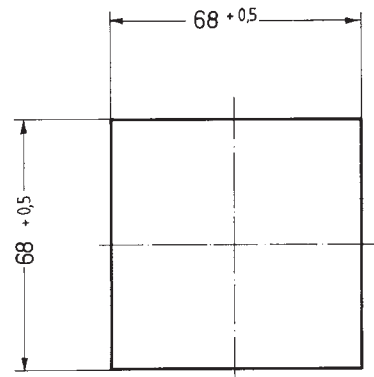

panel cut-out

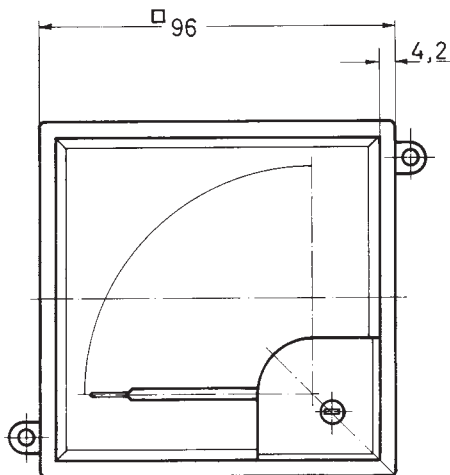

SQ 96 DS

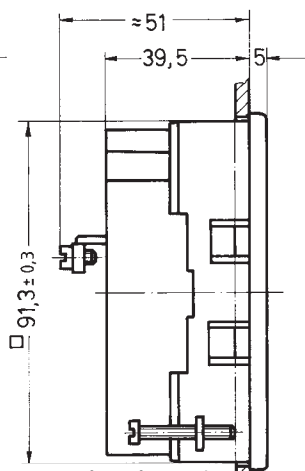

snap-in fixing for panel thickness up to 2.5 mm

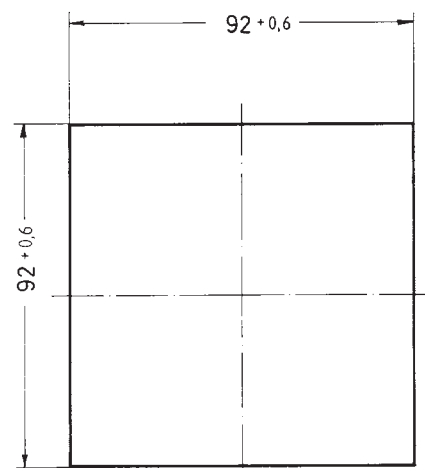

panel cut-out

Connections: voltmeters and ammeters up to 15 A M 4
 ammeters from 25 A to 40 A M 6
 ammeters from 60 A M 8

Protective covers acc. to VGB 4 for connection terminals available

Type SQ 48 DS on request also available with screw fixing

SQUARE MOVING COIL METERS

Square Panel Meters

"Ratioserie"

Moving Coil Meters

for direct current and direct voltage
with interchangeable scale

accuracy class 1.5, pointer deflection 240°

housing according to **DIN 43700**

Available housing types:

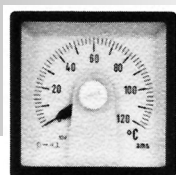

LQ 48 DS

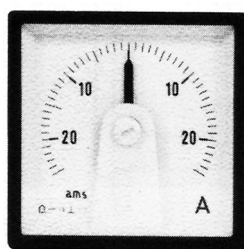

LQ 72 DS

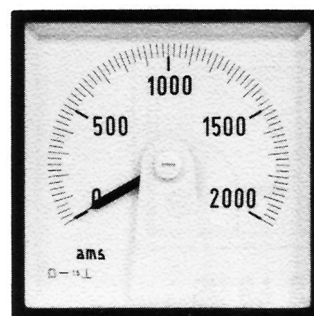

LQ 96 DS

SQUARE MOVING COIL METERS

	LQ 48 DS	LQ 72 DS	LQ 96 DS
Front frame	48 x 48 mm	72 x 72 mm	96 x 96 mm
Scale length approx.	70 mm	105 mm	150 mm
Weight approx.	0.2 kg	0.25 kg	0.3 kg

also available in size 144 x 144 mm, same dimensions as RQ 144 (see page QU/13)

Movement

moving coil with 240° pointer deflection

Bearing

pivots with spring mounted jewels

Pointer

beam-type knife-edge pointer

Housing

polycarbonate casing, self-extinguishing and drip-proof

Front frame colour

black, grey on request

Measuring ranges

Ammeters

Internal resistance/ ΔU

Voltmeters

Internal resistance

100 μA

4400 Ω

100 mV

200 Ω/V

150 μA

4000 Ω

150 mV

200 Ω/V

250 μA

2500 Ω

400 mV

1000 Ω/V

400 μA

2000 Ω

600 mV

1000 Ω/V

600 μA

1400 Ω

1 V

1000 Ω/V

1 mA

300 Ω

1.5 V

1000 Ω/V

1.5 mA

250 Ω

2.5 V

1000 Ω/V

2.5 mA

120 Ω

4 V

1000 Ω/V

4 mA

80 Ω

6 V

1000 Ω/V

6 mA

60 mV

10 V

1000 Ω/V

10 mA

60 mV

15 V

1000 Ω/V

15 mA

60 mV

25 V

1000 Ω/V

20 mA

60 mV

40 V

1000 Ω/V

25 - 600 mA

60 mV

60 V

1000 Ω/V

1 A

60 mV

100 V

1000 Ω/V

1.5 A

60 mV

150 V

1000 Ω/V

2.5 A

60 mV

250 V

1000 Ω/V

4 A

60 mV

400 V

1000 Ω/V

6 A

60 mV

500 V

1000 Ω/V

10 A

60 mV

600 V

1000 Ω/V

15 A

60 mV

25 A

60 mV

40 A

60 mV

60 A

60 mV

x) For operation with
separate shunts

60 mV x)

12 Ω

150 mV x)

30 Ω



Automatische Mess- und Steuerungstechnik GmbH 91275 Auerbach · Enge Gasse 1
91270 Auerbach · Postfach 1180

Phone +49 (0)96 43 / 92 05-0 Internet: www.ams-messtechnik.de
Fax +49 (0)96 43 / 92 05-90 e-mail: info@ams-messtechnik.de

Square Panel Meters

"Ratioserie"

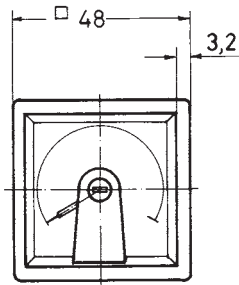

LQ 48 DS

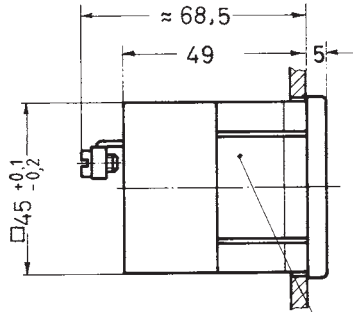

snap-in fixing for panel thickness up to 2.5 mm

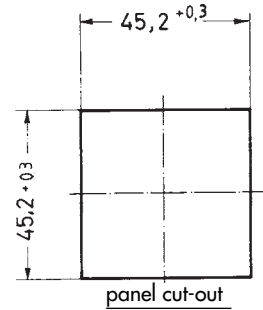

panel cut-out

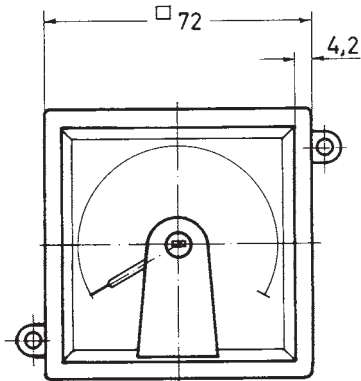

LQ 72 DS

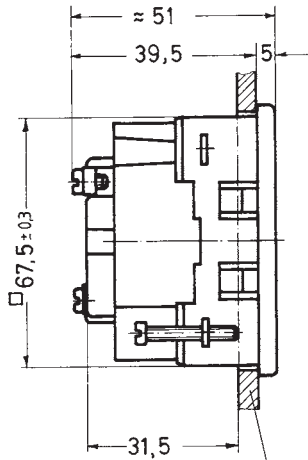

snap-in fixing for panel thickness up to 2.5 mm

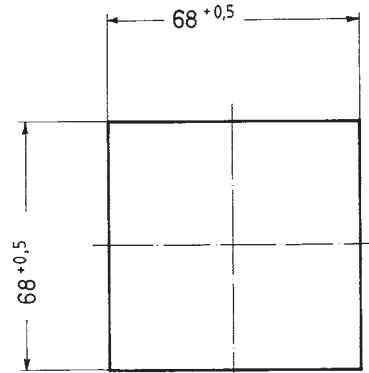

panel cut-out

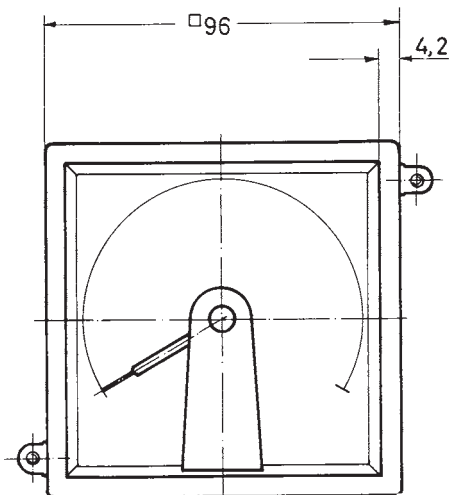

LQ 96 DS

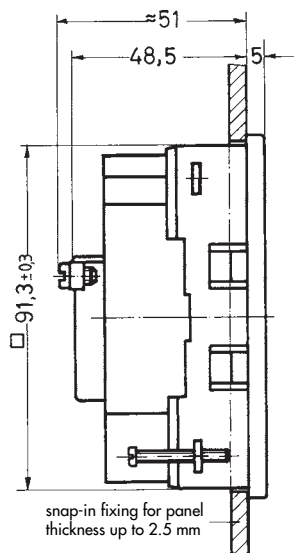

snap-in fixing for panel thickness up to 2.5 mm

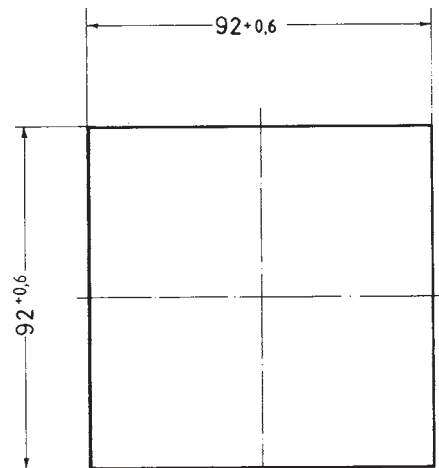

panel cut-out

Connections: voltmeters and ammeters up to 15 A
ammeters from 25 A to 40 A
ammeters from 60 A

M 4
M 6
M 8

Protective covers acc. to VGB 4 for connection terminals available

SQUARE MOVING COIL METERS

Square Panel Meters

Steel-Sheet Series

Moving Coil Meters

for direct current and direct voltage
accuracy class 1.5

housing acc. to **DIN 43700**

Available housing types:

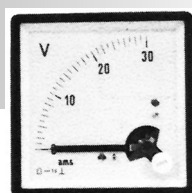

RQ 72 DS

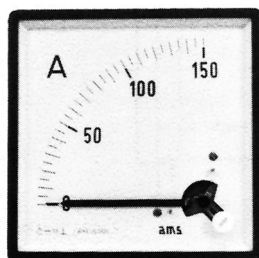

RQ 96 DS

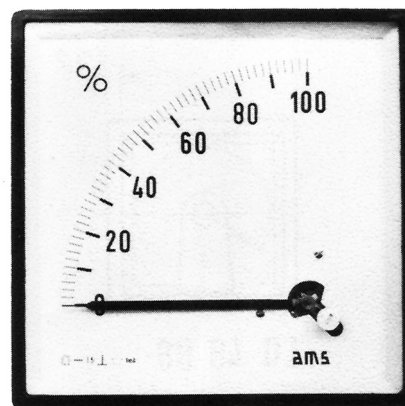

RQ 144 DS

SQUARE MOVING COIL METERS

	SQ 48 DS	RQ 96 DS	RQ 144 DS
Front frame	48 x 48 mm	96 x 96 mm	144 x 144 mm
Scale length approx.	40 mm	97 mm	142 mm
Weight approx.	0.1 kg	0.3 kg	0.6 kg

Movement	moving coil with core magnet (immune to magnetic fields)
Bearing	pivots with spring mounted jewel
Pointer	beam-type knife-edge pointer
Housing	steel-sheet casing, plastic base plate
Front frame colour	black, grey on request

Measuring ranges	Ammeters		Voltmeters	
	Internal resistance / ΔU		Internal resistance	
	RQ 72 + 96	RQ 144		
100 μ A	4000 Ω	6300 Ω	100 mV	200 Ω /V
150 μ A	4000 Ω	6300 Ω	150 mV	200 Ω /V
250 μ A	1300 Ω	2600 Ω	400 mV	1000 Ω /V
400 μ A	1100 Ω	1300 Ω	600 mV	1000 Ω /V
600 μ A	380 Ω	380 Ω	1 V	1000 Ω /V
1 mA	80 Ω	85 Ω	1.5 V	1000 Ω /V
1.5 mA	30 Ω	47 Ω	2.5 V	1000 Ω /V
2.5 mA	13 Ω	16 Ω	4 V	1000 Ω /V
4 mA	11 Ω	10 Ω	6 V	1000 Ω /V
6 mA	5.5 Ω	5.5 Ω	10 V	1000 Ω /V
10 mA	3 Ω	3 Ω	15 V	1000 Ω /V
15 mA	2.8 Ω	2.8 Ω	25 V	1000 Ω /V
20 mA	2.3 Ω	2.3 Ω	40 V	1000 Ω /V
25 - 600 mA	60 mV	60 mV	60 V	1000 Ω /V
1 A	60 mV	60 mV	100 V	1000 Ω /V
1.5 A	60 mV	60 mV	150 V	1000 Ω /V
2.5 A	60 mV	60 mV	250 V	1000 Ω /V
4 A	60 mV	60 mV	400 V	1000 Ω /V
6 A	60 mV	60 mV	500 V	1000 Ω /V
10 A	60 mV	60 mV	600 V	1000 Ω /V
15 A	60 mV	60 mV		
25 A	60 mV	60 nV		
40 A	60 mV	60 mV		
60 A	60 mV	60 mV		
x) For operation with separate shunts	60 mV x)	5 Ω	5 Ω	

Square Panel Meters

Steel-Sheet Series

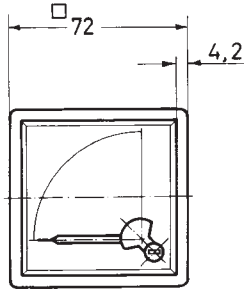

RQ 72 DS

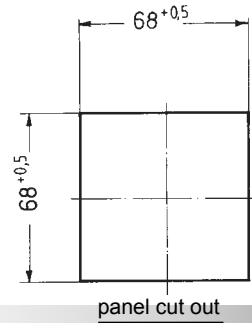
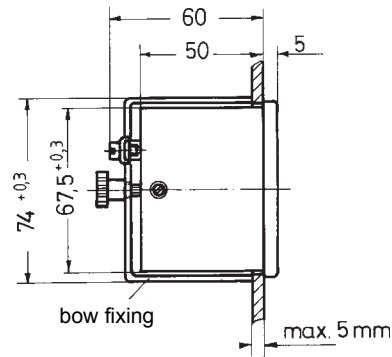

panel cut out

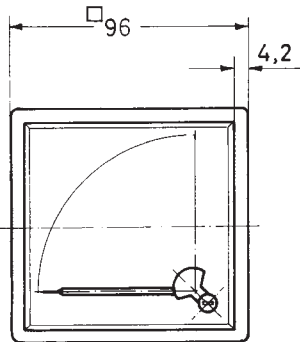

RQ 96 DS

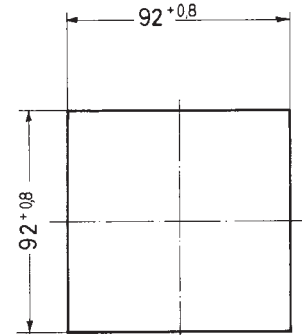
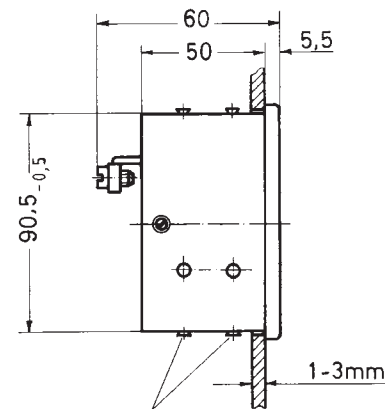

panel cut out

spring fixing acc. to DIN 43 853, Form A;
Form B for panel thickness >3mm

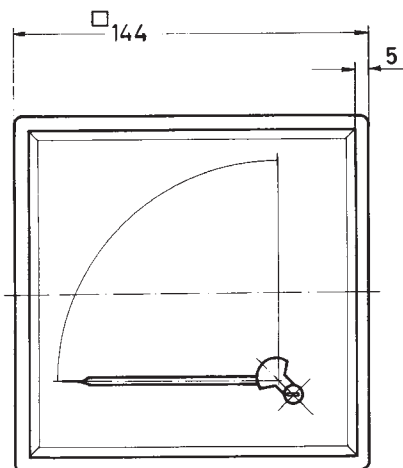

RQ 144 DS

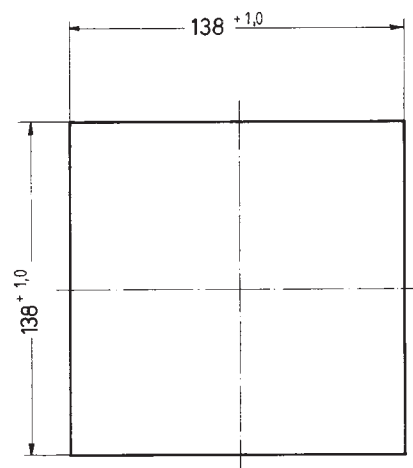
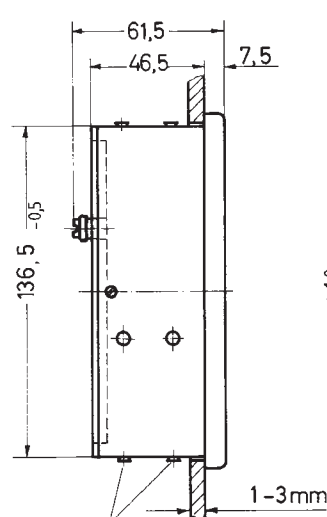

panel cut out

spring fixing acc. to DIN 43 853, Form A;
Form B for panel thickness >3mm

Connections: voltmeters and ammeters up to 15 A M 4
ammeters from 25 A M 6
ammeters from 60 A M 8

SQUARE MOVING COIL METERS

Square Panel Meters

Special Designs

Square Moving Coil Meters

SQUARE MOVING COIL METERS

Housing

Front frame colours

standard: black
special version: grey
other colours on request

Front glass

standard: silicate glass
special version: anti-glare glass, double layer safety glass

Splash protection

standard: IP 52
special version: IP 54
sizes Q 72 and Q 96 with sealing and protective glass
sizes Q 48, Q 72 and Q 96 with rubber sealing
(panel cut-out about 1 mm bigger)

Illumination

for sizes Q 72, Q 96, Q 144

Scales

Coloured scales

scale background black, scale division and numbering white or yellow
other colours on request

Divisions

coloured scale divisions or marks
two or more scale divisions possible
calibration according to a curve or table
calibration in a different measurement variable

Movement

Internal resistance voltmeter

standard approx. 1000 Ω/V
special versions: 2000 Ω/V
5000 Ω/V
10,000 Ω/V

Initial part of deflection stretched

approx. 25% of the full-scale value at the center of the scale
(not for LQ and LDS)

Measuring rectifier (for measuring AC)

voltmeter 6 - 600 V installed in housing
ammeter up to 20 mA installed in housing
from 1 to 25 A with separate current matching transformer n/0.01 A
current matching transformer for types SQ 96, LQ 96, RQ 144 and LDS 144
installed in housing

Accuracy class

class 1 on request

2nd measuring range

for ammeters or voltmeters on request

Live-zero

4 - 20 mA (electrically suppressed zero)

Square Panel Meters

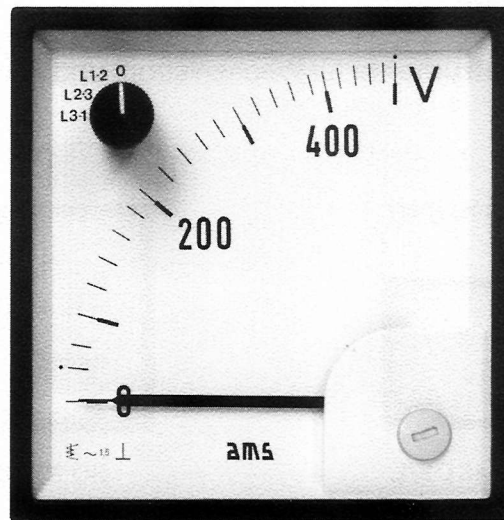
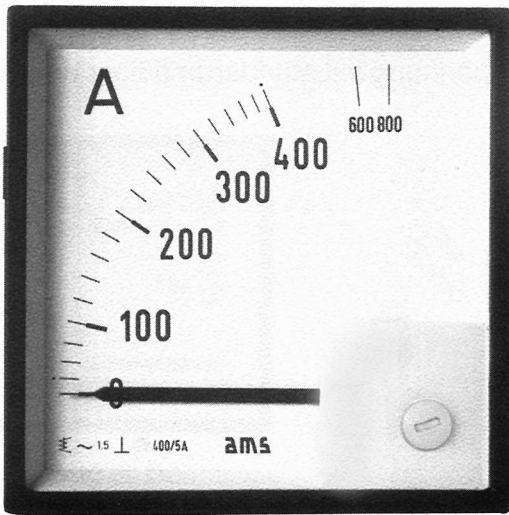

Moving iron meters

- "Ratioserie"
- steel-sheet series

- Ratioserie in polycarbonate housing with interchangeable scale
- Steel-sheet series with steel housing body and aluminium front frame (scale not interchangeable)
- Magnetic shielding
- Ratioserie with snap-in fixing

SQUARE MOVING IRON METERS

Square Panel Meters

"Ratioserie"

Moving Iron Meters

for alternating current and alternating voltage
with interchangeable scale

accuracy class 1.5

Available housing types:

housing according to **DIN 43700**

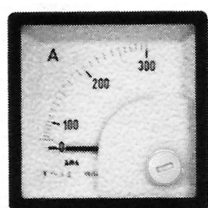

SQ 48 DE/L

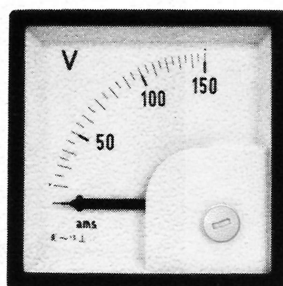

SQ 72 DE

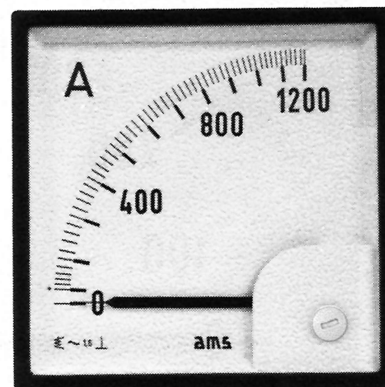

SQ 96 DE

SQUARE MOVING IRON METERS

	SQ 48 DE/L	SQ 72 DE	SQ 96 DE
Front frame	48 x 48 mm	72 x 72 mm	96 x 96 mm
Scale length approx.	40 mm	62 mm	97 mm
Weight approx.	0.1 kg	0.15 kg	0.2 kg

Movement

moving iron with magnetic shielding

Damping

silicone oil

Bearing

pivot with spring mounted jewel

Pointer

beam-type knife-edge pointer

Housing

thermoplastic, i.e. self extinguishing and drip-proof polycarbonate

Front frame colour

black, grey on request

Measuring ranges

Ammeters

Voltmeters

100 / 200 mA

10 V

150 / 300 mA

15 V

250 / 500 mA

25 V

400 / 800 mA

40 V

600 / 1200 mA

60 V

1 / 2 A

100 V

1.5 / 3 A

150 V

2.5 / 5 A

250 V

4 / 8 A

300 V

6 / 12 A

400 V

10 / 20 A

500 V

15 / 30 A

600 V

25 / 50 A

100 V (for operation with transformer)

40 / 80 A

110 V (for operation with transformer)

60 / 120 A

100 / 200 A

n / 5 A (for operation with transformer)

n / 1 A (for operation with transformer)

Type SQ 48 DE/L for direct connection only up to 25/50 A
ammeters also available without overload scale

Square Panel Meters

"Ratioserie"

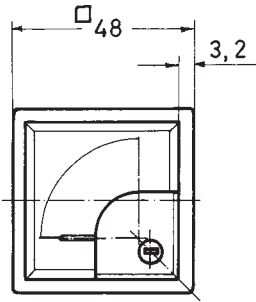

SQ 48 DE/L

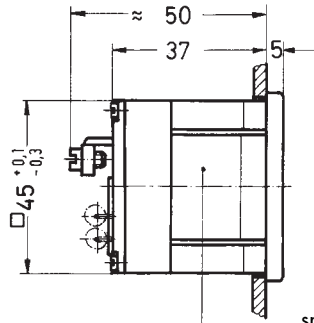

snap-in fixing for panel thickness up to 2.5 mm

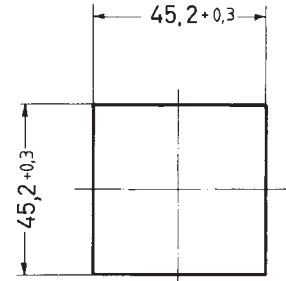

panel cut-out

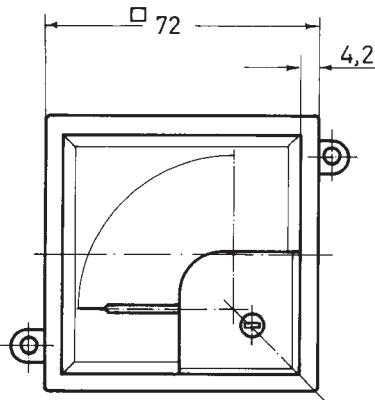

SQ 72 DE

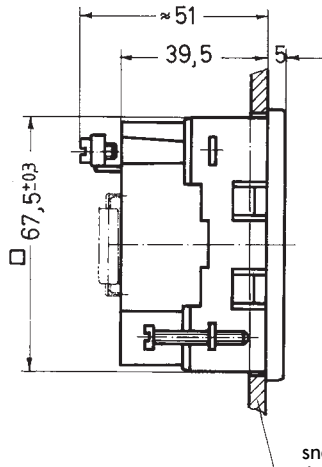

snap-in fixing for panel thickness up to 2.5 mm

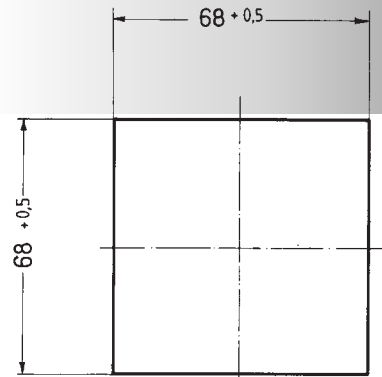

panel cut-out

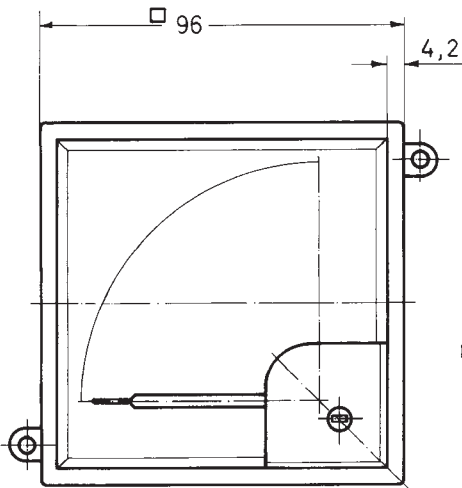

SQ 96 DE

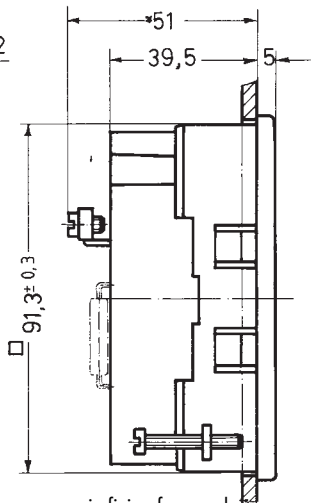

snap-in fixing for panel thickness up to 2.5 mm

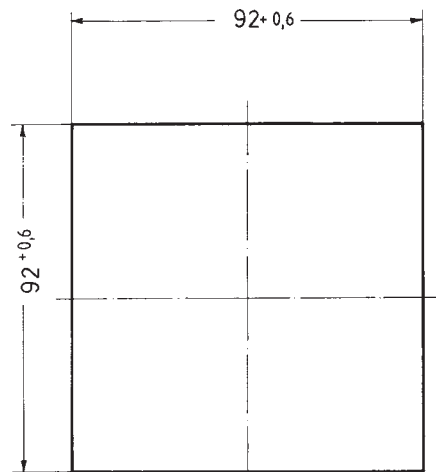

panel cut-out

Connections: voltmeters and ammeters up to 15 A M 4
 ammeters from 25 A to 40 A M 6
 ammeters from 60 A M 8

Protective covers acc. to VGB 4 for connection terminals available

Type SQ 48 DS on request also available with screw fixing

SQUARE MOVING IRON METERS

Square Panel Meters

Steel-Sheet Series

Moving Iron Meters

for alternating current and alternating voltage

accuracy class 1.5

housing acc. to **DIN 43700**

Available housing types:

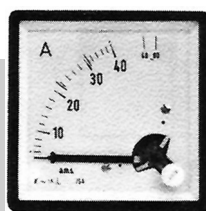

RQ 72 DE

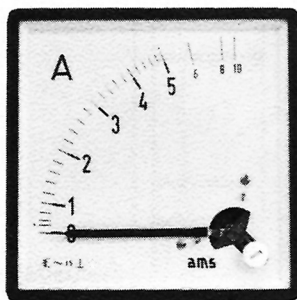

RQ 96 DE

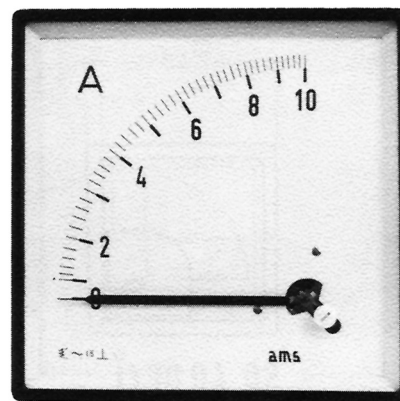

RQ 144 DE

Front frame	RQ 72 DE	RQ 96 DE	RQ 144 DE
Scale length approx.	72 x 72 mm	96 x 96 mm	144 x 144 mm
Weight approx.	68 mm	97 mm	142 mm
	0.25 kg	0.3 kg	0.6 kg

Movement

Damping

Bearing

Pointer

Housing

Front frame colour

Measuring ranges

moving iron with magnetic shielding

silicone oil

pivot with spring mounted jewel

beam-type knife-edge pointer

steel-sheet casing, plastic base plate

black, grey on request

Ammeters

100 / 200 mA

150 / 300 mA

250 / 500 mA

400 / 800 mA

600 / 1200 mA

1 / 2 A

1.5 / 3 A

2.5 / 5 A

4 / 8 A

6 / 12 A

10 / 20 A

15 / 30 A

25 / 50 A

40 / 80 A

60 / 120 A

100 / 200 A

n / 5 A (for operation with transformer)

n / 1 A (for operation with transformer)

ammeters also available without overload scale

*) for RQ 72 DE and RQ 96 in separate housing

Voltmeters

10 V

15 V

25 V

40 V

60 V

100 V

150 V

250 V

300 V

400 V

500 V

600 V *)

100 V (for operation with transformer)

110 V (for operation with transformer)

SQUARE MOVING IRON METERS

Square Panel Meters

Steel-Sheet Series

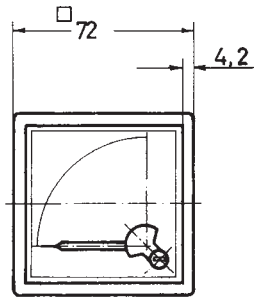

RQ 72 DE

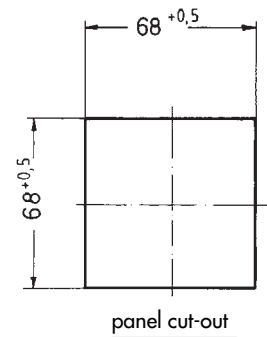
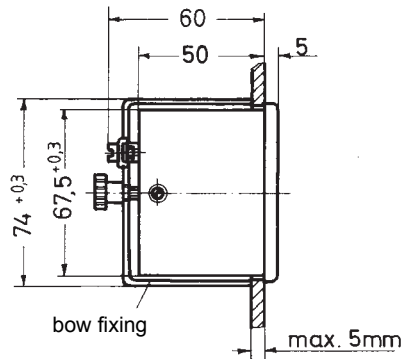

panel cut-out

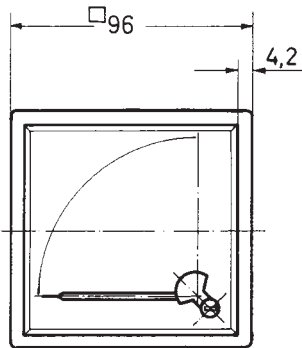

RQ 96 DE

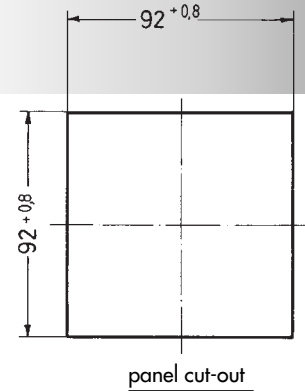
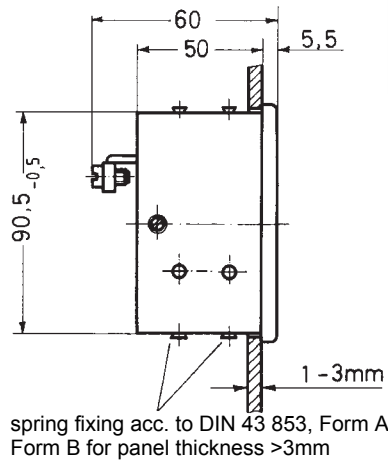

panel cut-out

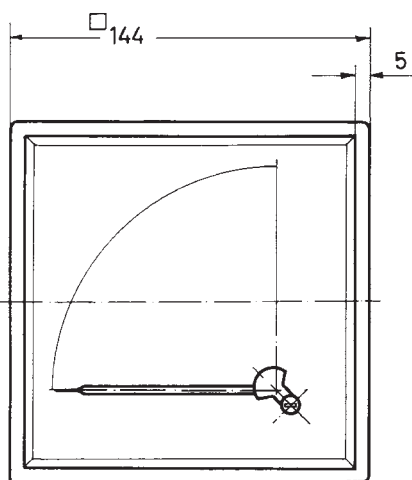

RQ 144 DE

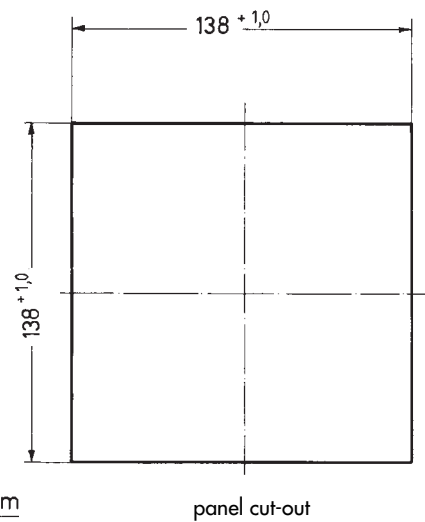
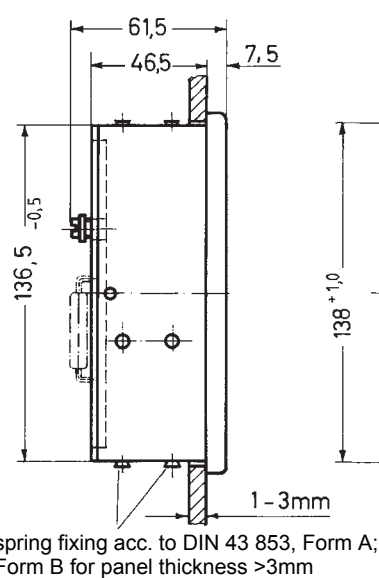

panel cut-out

Connections: voltmeters and ammeters up to 15 A M 4
 ammeters from 25 A M 6
 ammeters from 60 A M 8

SQUARE MOVING IRON METERS

Square Panel Meters

"Ratioserie"

Moving Iron Voltmeter with built-in voltmeter switcher accuracy class 1.5

These meters are used for measuring voltage in three-phase AC power grids. With the built-in switcher they can measure voltage between two phases or between phase and neutral wire.

The previously used external voltmeter switch is not necessary anymore.

Available housing types:

housing according to **DIN 43700**

SQUARE MOVING IRON METERS

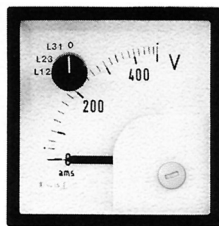

SQ 72 DE/U

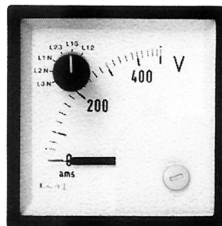

SQ 72 DE/U2

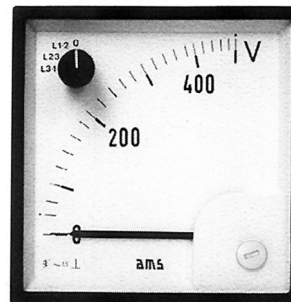

SQ 96 DE/U

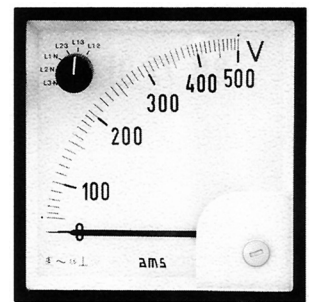

SQ 96 DE/U2

	SQ 72 DE/U - SQ 72 DE/U2	SQ 96 DE/U - SQ 96 DE/U2
Front frame	72 x 72 mm	96 x 96 mm
Scale length approx.	58 mm	93 mm
Weight approx.	0.18 kg	0.23 kg

Movement	moving iron with magnetic shielding
Damping	silicone oil
Bearing	pivot with spring mounted jewel
Pointer	beam-type knife-edge pointer
Housing	thermoplastic, i.e. self extinguishing and drip-proof polycarbonate
Front frame colour	black, special edition grey RAL 7037

Measuring ranges	SQ 72 DE/U	SQ 72 DE/U2
	SQ 96 DE/U	SQ 96 DE/U2
	3 x 0 - 260 V	3 x 0 - 260 V
	3 x 0 - 500 V	3 x 0 - 500 V

Switch positions	0, L1-2, L2 -3, L3 -1	L1-2, L1-3, L2 -3 L1 - N, L2 - N, L3 - N
-------------------------	-----------------------	---------------------------------------------

Square Panel Meters

"Ratioserie"

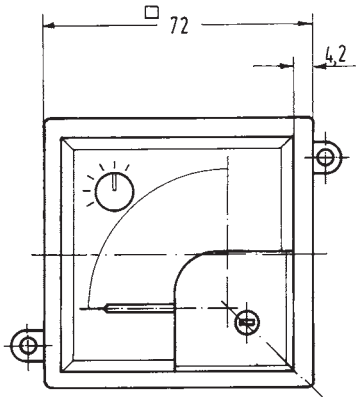

SQ 72 DE/U
SQ 72 DE/U2

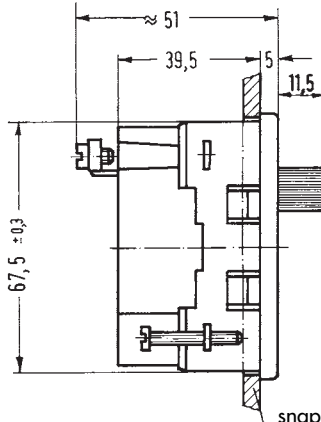

snap-in fixing for panel thickness up to 2.5 mm

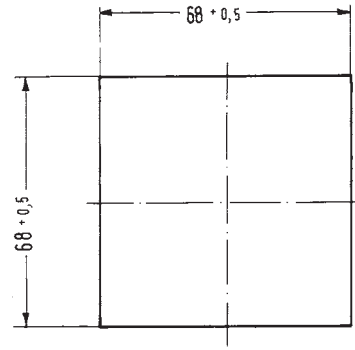

panel cut-out

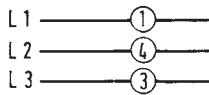

terminal assignment
SQ 72 DE/U

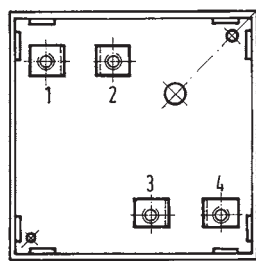

terminal layout

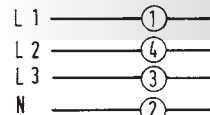

terminal assignment
SQ 72 DE/U2

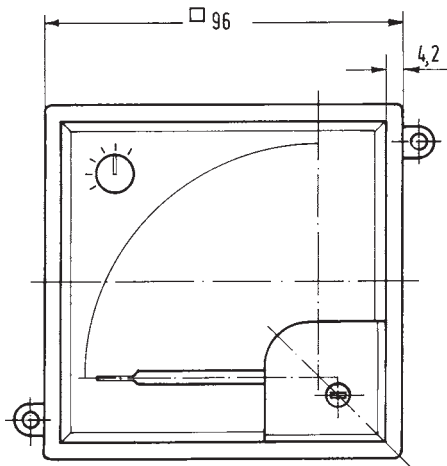

SQ 96 DE/U
SQ 96 DE/U2

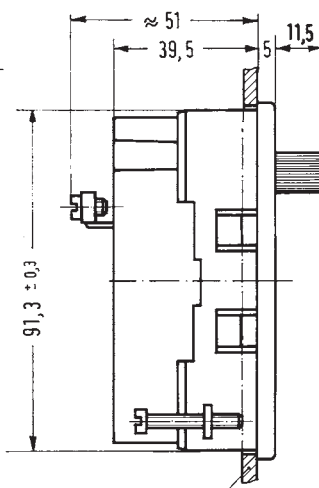

snap-in fixing for panel thickness up to 2.5 mm

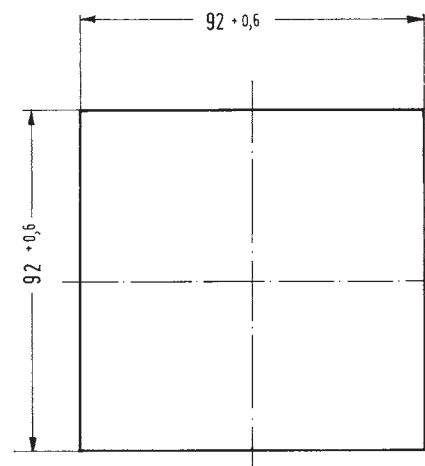

panel cut-out

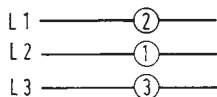

terminal assignment
SQ 96 DE/U

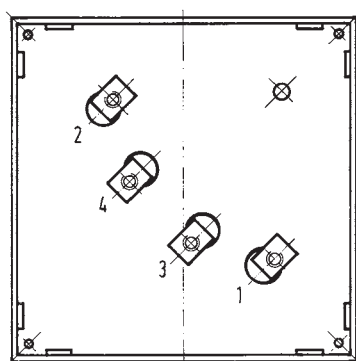

terminal layout

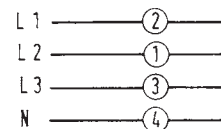

terminal assignment
SQ 96 DE/U2

Square Panel Meters

Special Designs

Square Moving Iron Meters

Housing

Front frame colours

standard: black
special version: grey
other colours on request

Front glass

standard: silicate glass
special version: anti-glare glass, double layer safety glass

Splash protection

standard: IP 52
special version: IP 54
sizes Q 72 and Q 96 with sealing and protective glass
sizes Q 48, Q 72 and Q 96 with rubber sealing
(panel cut-out about 1 mm bigger)

Illumination

for sizes Q 72, Q 96, Q 144

Scales

Coloured scales

scale background black, scale division and numbering white or yellow
other colours on request

Divisions

coloured scale divisions or marks
two or more scale divisions possible
calibration according to a curve or table
calibration in a different measurement variable

Movements

Overload range ammeters

2-fold standard,
up 25 A direct connection 5-fold (not for SQ 48 DE/L)

2nd measuring range

voltmeters up to 300 V
ammeters up to 10 A

Frequency

standard: 16 $\frac{2}{3}$ - 100 Hz
special version: 100 - 400 Hz

Square Panel Meters

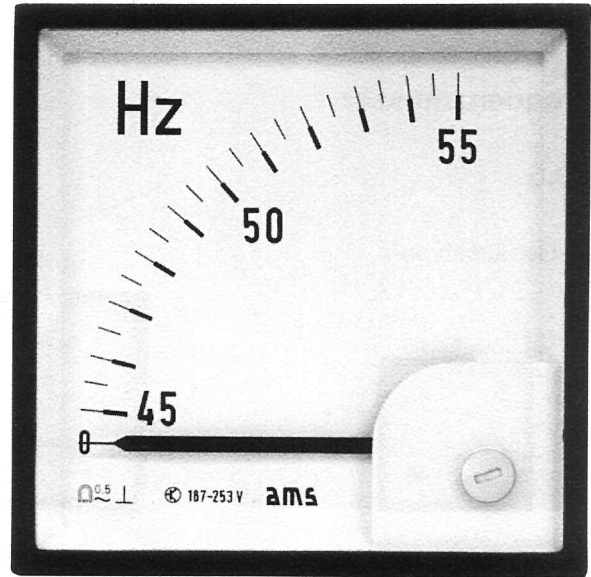
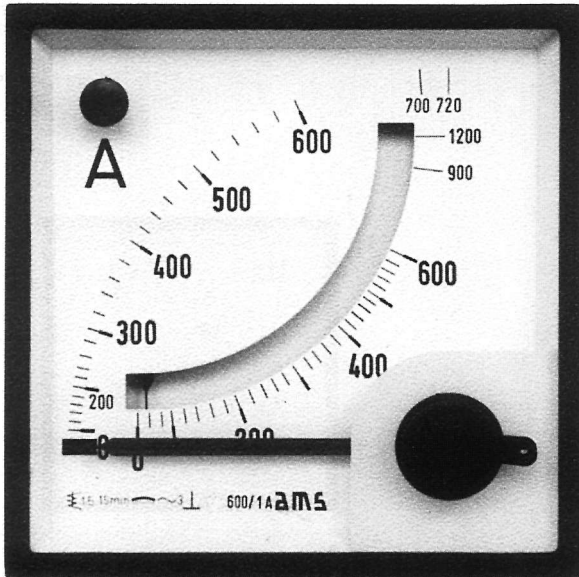

Pointer Frequency Meter – Ratio-Serie Bimetal Meter – Ratio-Serie

- Meters with snap-in fixing
- Interchangeable scale by default
- Pointer frequency meter for $16\frac{2}{3}$, 50, 60, 400 Hz
- Bimetal meter with factor disc
- Bimetal meter time lag 15 minutes or 8 minutes
- Bimetal meter with wire sealable reset button

SQUARE PANEL METERS

Square Panel Meters

"Ratioserie"
pointer frequency meter
accuracy class 0.5

housing according to **DIN 43700**

Available housing types:



ZQ 48 DS

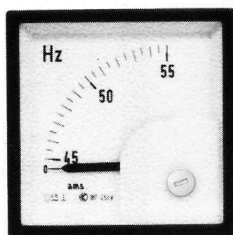

ZQ 72 DS



ZQ 96 DS

SQUARE PANEL METERS

	ZQ 48 DS	ZQ 72 DS	ZQ 96 DS
Front frame	48 x 48 mm	72 x 72 mm	96 x 96 mm
Scale length approx.	40 mm	62 mm	97 mm
Weight approx.	0.15 kg	0.2 kg	0.4 kg

Movement

Bearing

Pointer

Housing

Permissible

voltage fluctuation

Warm-up time

moving coil with core magnet and built-in transducer

pivots with spring mounted jewel

beam-type knife-edge pointer

polycarbonate casing, self-extinguishing and drip-proof

-15% ... +10%

approx. 5 min.

Measuring ranges

45 - 50 - 55 Hz

55 - 60 - 65 Hz

Nominal voltage

100, 230, 400 V *)

More measuring ranges on request.

Size 144 x 144 mm also available in steel-sheet housing.

*) For 400 V fixing with angle bracket only.

Square Panel Meters

"Ratioserie"

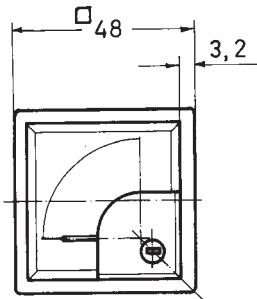

ZQ 48 DS

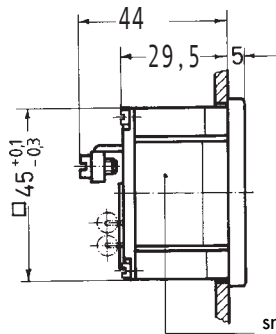

snap-in fixing for panel thickness up to 2.5 mm

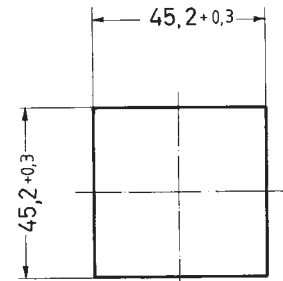

panel cut-out

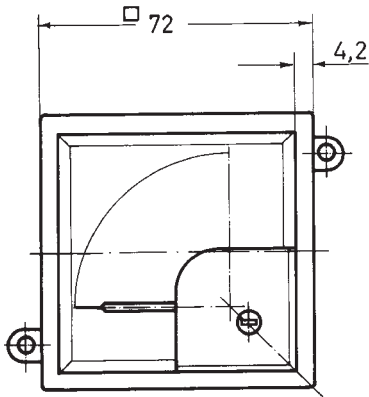

ZQ 72 DS

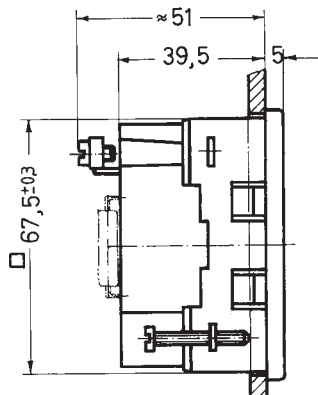

snap-in fixing for panel thickness up to 2.5 mm

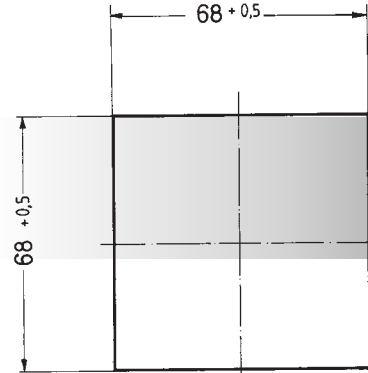

panel cut-out

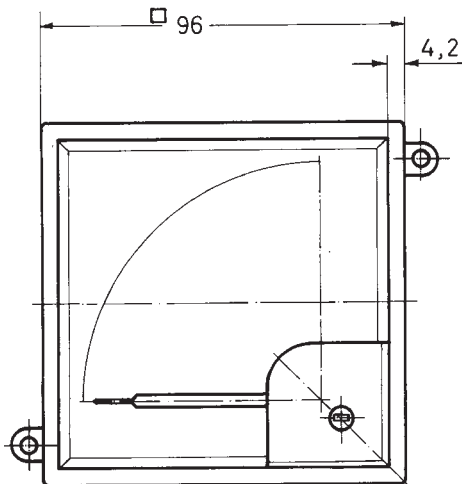

ZQ 96 DS

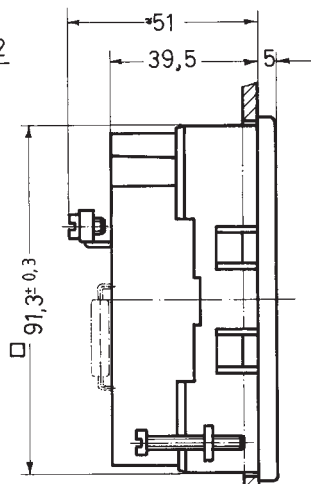

snap-in fixing for panel thickness up to 2.5 mm

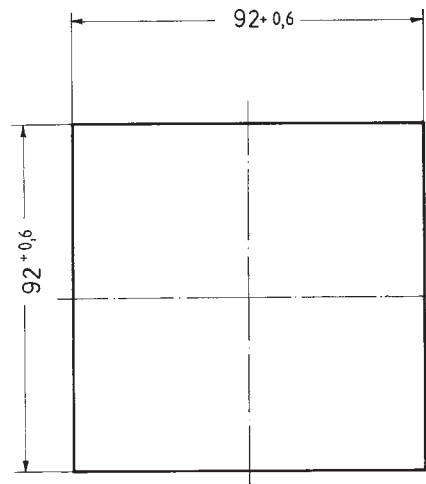

panel cut-out

Connections: M4

The types ZQ 72 DS and ZQ 96 DS are also available with snap-in fixing.

Type ZQ 48 DS is available in a special version with screw fixing.

Protective covers for connection terminals acc. to VGB 4 optionally available.

SQUARE PANEL METERS

Square Panel Meters

"Ratioserie"

peak-current meter

peak-current meter with instantaneous value

housing according to **DIN 43700**

Available housing types:

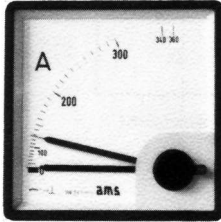

BiQ 72

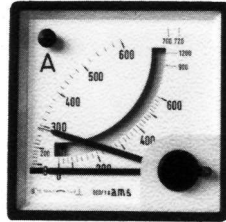

BiMQ 72

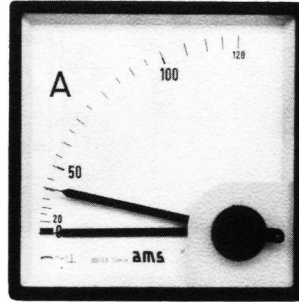

BiQ 96

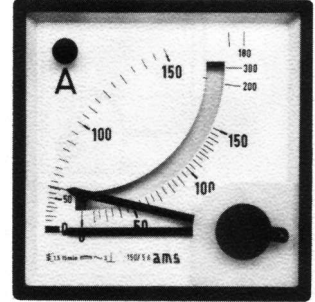

BiMQ 96

SQUARE PANEL METERS

	BiQ 72	BiMQ 72	BiQ 96	BiMQ 96
Front frame	72 x 72 mm	72 x 72 mm	96 x 96 mm	96 x 96 mm
Scale length approx.	60 mm	60 mm / 42 mm	97 mm	97 mm / 73 mm
Weight approx.	0.15 kg	0.18 kg	0.20 kg	0.25 kg

Movement	- BiQ	bimetal	
	- BiMQ	bimetal + moving iron movement	
Accuracy class	- BiQ	3	
	- BiMQ	3/1.5	
Pointer	- BiQ	black main pointer and red slave pointer	
	- BiMQ	with additional black pointer for the moving iron movement	
Pointer reset		the reset button of the red slave pointer is sealable	
Housing		polycarbonate casing, self-extinguishing and drip-proof	
Front frame colour		black, grey on request	
Time lag bimetal		standard 15 min; on request 8 min.	
Internal consumption		BiQ 5A, 15 min approx. 2.8 VA	
		BiMQ 5A, 15 min approx. 3.8 VA	
Overload		permanently 1.2-fold	
		briefly 10-fold (1 sec.)	
Measuring ranges		Bimetal / moving iron	Current transformer connection
Type	BiQ 72	0 - 1.2 A -	n / 1 A
		0 - 6.0 A -	n / 5 A
	BiMQ 72	0 - 1.2 A / 0 - 1/2 A	n / 1 A
		0 - 6.0 A / 0 - 5/10 A	n / 5 A
	BiQ 96	0 - 1.2 A -	n / 1 A
		0 - 6.0 A -	n / 5 A
	BiMQ 96	0 - 1.2 A / 0 - 1/2 A	n / 1 A
		0 - 6.0 A / 0 - 5/10 A	n / 5 A

Scale divisions according to DIN standard

Square Panel Meters

"Ratioserie"

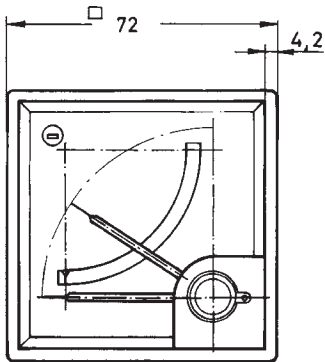

BiQ 72+BiMQ 72

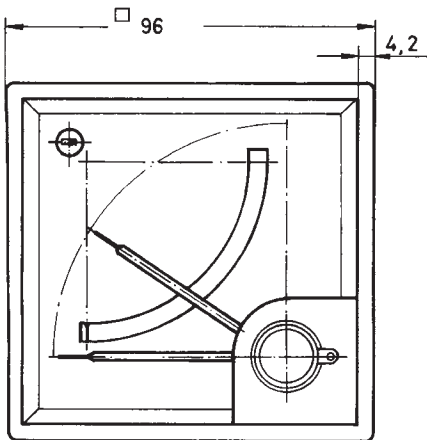
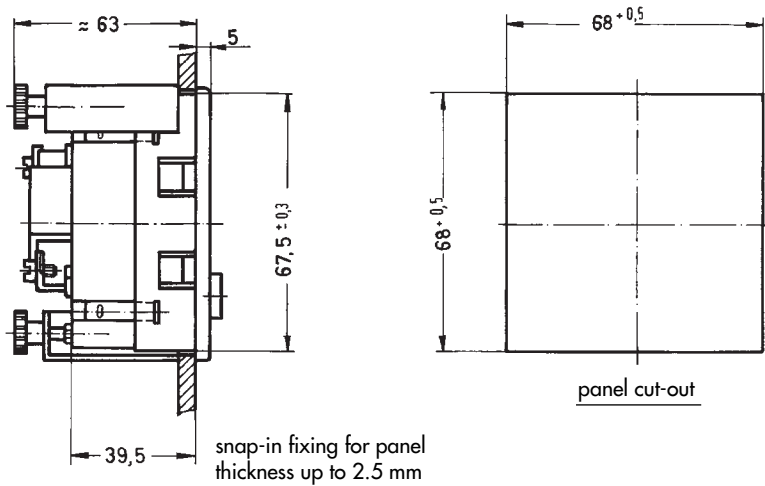

BiQ 96 + BiMQ 96

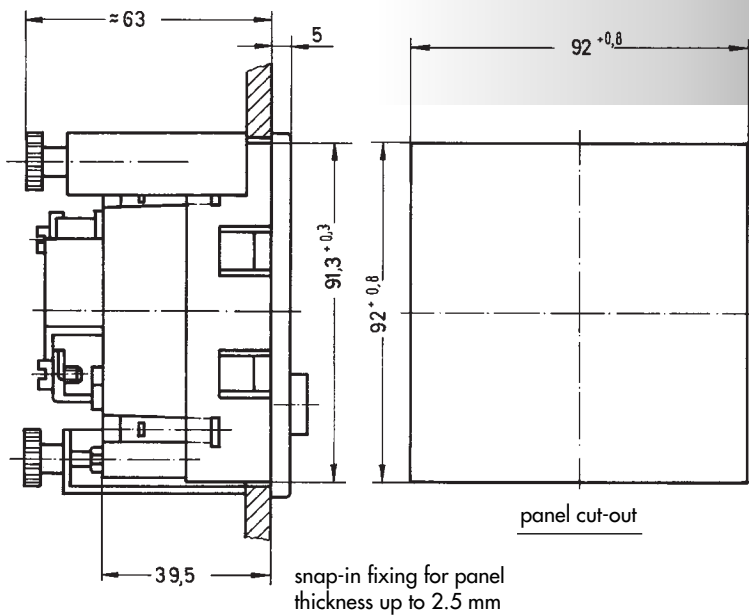

constants disc for
BiQ 72+BiQ 96 u. BiMQ 72 + BiMQ 96

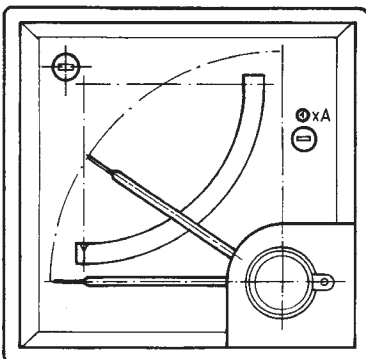

adjustable constants: 1-1.5-2-2.5-3-4-5-6-8-10

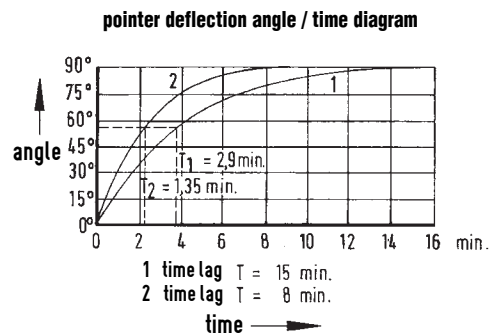

SQUARE PANEL METERS

Square Panel Meters

"Ratioserie" peak-current meter with interchangeable scale

housing according to **DIN 43700**

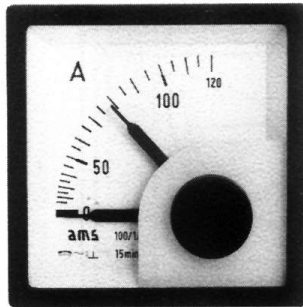

BIQ 48

Front frame	48 x 48 mm according to DIN 43718/s
Scale length approx.	38 mm
Weight approx.	0.15 kg
Movement	bimetal movement
Accuracy class	3
Pointer	black main pointer and red slave pointer
Pointer reset	the reset button of the red slave pointer is sealable
Housing	polycarbonate casing, self-extinguishing and drip-proof
Front frame colour	black, grey on request
Fixing	snap-in fixing, screw fixing optional
Time lag	standard 15 min; on request 8 min
Internal consumption	5A, 15 min approx. 2.5 VA 1A, 15 min approx. 1.5 VA
Overload	permanent 1.2 x I _N briefly 10 x I _N (1 sec.)
Measuring ranges	0 - 1.2 A for transformer n / 1 A or 0 - 6 A for transformer n / 5 A
Scale divisions	according to DIN standard for transformer connection

Square Panel Meters

"Ratioserie"

BiQ 48

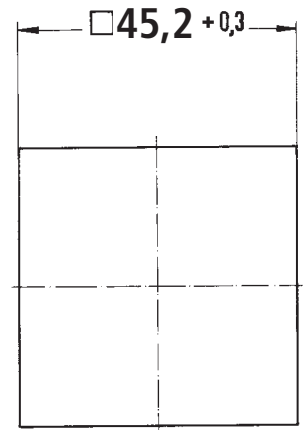
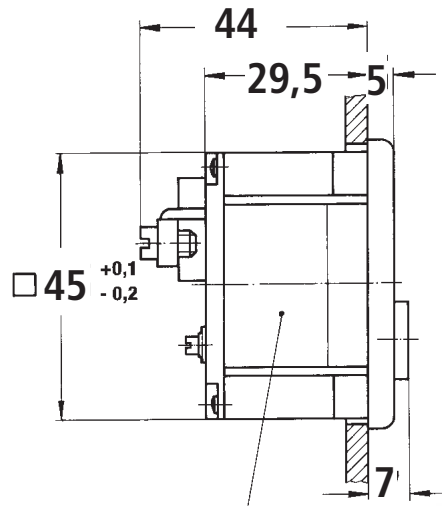
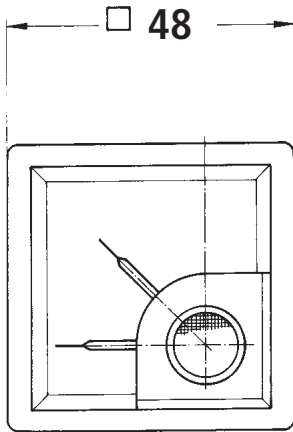

panel cut-out

snap-in fixing
also available with angle fastener

SQUARE PANEL METERS

Square Panel Meters

Special Designs

Square Pointer Frequency Meter

Square Bimetal Meter

Housing

Front frame colour

standard: black
special version: grey
other colours on request

Front glass

Splash protection

standard: silicate glass
standard: IP 52
special version: IP 54 (not for bimetal meters)
rubber sealing for Q 48, Q 72 and Q 96
(panel cutout approximately 1 mm bigger)
for pointer frequency meter ZQ 72 DS and ZQ 96 DS

Illumination

Scales

Coloured scales

scale background black, scale division and numbering white or yellow
other colours on request

Constants disc

coloured scale divisions or marks
types BiQ and BiMQ 72 and 96, with factors adjustable on the front:
1 - 1.5 - 2 - 2.5 - 3 - 4 - 5 - 6 - 8 - 10

Movements

Pointer frequency meters

intermediate ranges on request

Rectangular Panel Meters

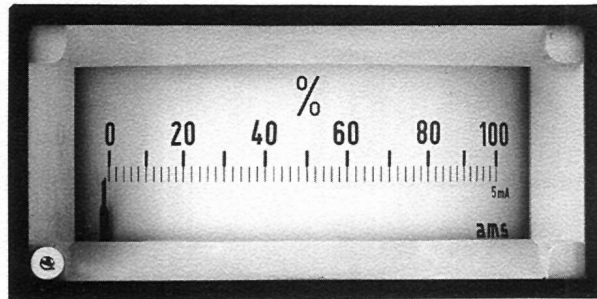

Moving coil edgewise meters Moving coil slim-line meters

- Edgewise meters in steel-sheet housing
- Slim-line meters in polycarbonate housing
- Available for mounting vertically or horizontally
- With built-in rectifier for AC input

RECTANGULAR PANEL METERS

Rectangular Panel Meters

**Edgewise moving coil meters
direct current and direct voltage
accuracy class 1.5**

housing according to **DIN 43700**

Available housing types:



Pr 72 x 36

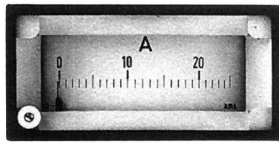

Pr 96 x 48

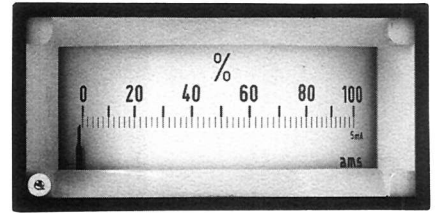

Pr 144 x 72

	Pr 72 x 36	Pr 96 x 48	Pr 144 x 72
Front frame	72 x 36 mm	96 x 48 mm	144 x 72 mm
Scale length approx.	46 mm	61 mm	103 mm
Weight approx.	0.1 kg	0.3 kg	1.2 kg

Movement	moving coil with core magnet (immune to magnetic fields)
Bearing	pivot with spring-loaded jewel
Pointer	beam-type knife-edge pointer
Mounting version	choose from horizontal or vertical mounting
Housing	steel sheet, black-painted
Front frame	black, grey on request

RECTANGULAR PANEL METERS

Measuring ranges	Ammeters	Internal resistance /Δ U			Volts
		Pr 72 x 36	Pr 96 x 48	Pr 144 x 72	
50 μA	4800 Ω	3900 Ω	6000 Ω	100 mV	
100 μA	3500 Ω	840 Ω	6000 Ω	150 mV	
150 μA	1500 Ω	590 Ω	2900 Ω	400 mV	
250 μA	550 Ω	460 Ω	1300 Ω	600 mV	
400 μA	220 Ω	145 Ω	380 Ω	1 V	
600 μA	95 Ω	75 Ω	170 Ω	1.5 V	
1 mA	35 Ω	30 Ω	110 Ω	2.5 V	
1.5 mA	18 Ω	20 Ω	40 Ω	4 V	
2.5 mA	10 Ω	7 Ω	17 Ω	6 V	
4 mA	4 Ω	3 Ω	10 Ω	10 V	
6 mA	3.5 Ω	2.4 Ω	10 Ω	15 V	
10 mA	2.5 Ω	2.2 Ω	6 Ω	25 V	
15 mA	2.2 Ω	2 Ω	4 Ω	40 V	
20 mA	2.0 Ω	2 Ω	1.5 Ω	60 V	
25-600 mA	60 mV	60 mV	60 V	100 V	
1 A	60 mV	60 mV	60 V	150 V	
1.5 A	60 mV	60 mV	60 V	250 V	
2.5 A	60 mV	60 mV	60 V	900 V	
4 A	60 mV	60 mV	60 V	500 V	
6 A	60 mV	60 mV	60 V	600 V	
10 A	60 mV	60 mV	60 V		
4 -20 A	12 Ω	12 Ω	12 Ω		
60 mV x)	12 Ω	12 Ω	12 Ω		

Ri approx.
1000 Ω/V

x) for operation with a separate shunt

tolerance of the internal resistance ± 20%

Rectangular Panel Meters

Edgewise moving coil meters

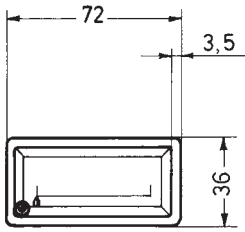

PR 72x36

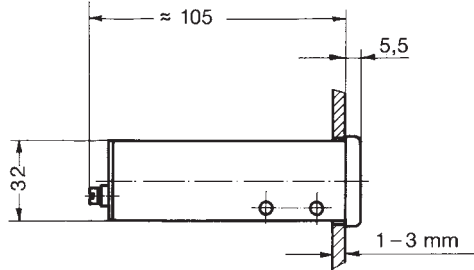

spring fixing acc. to
DIN 43 853, Form A

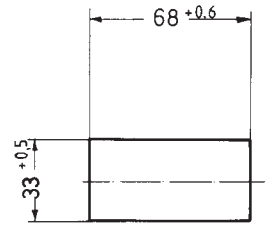

panel cut out

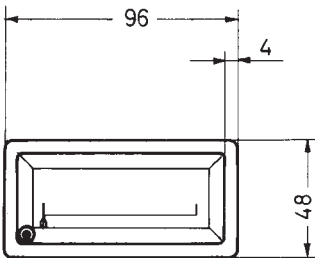

PR 96 x 48

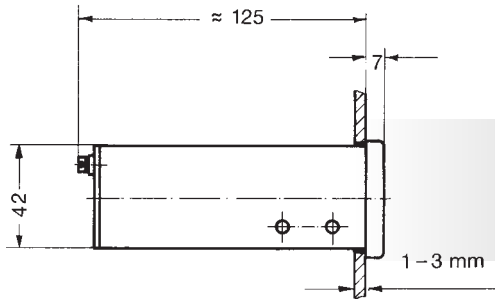

spring fixing acc. to
DIN 43 853, Form A

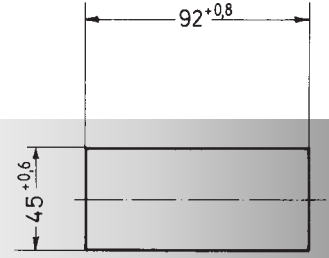

panel cut out

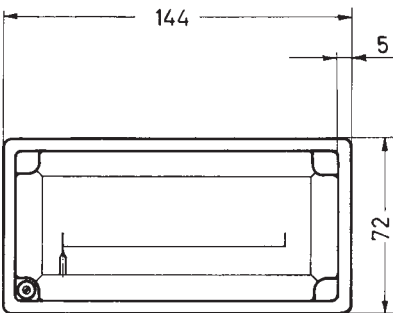

PR 144x72

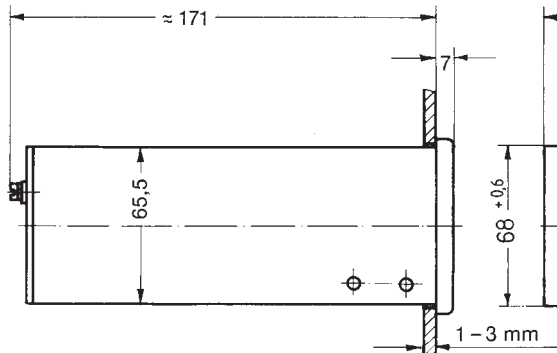

spring fixing acc. to
DIN 43 853, Form A

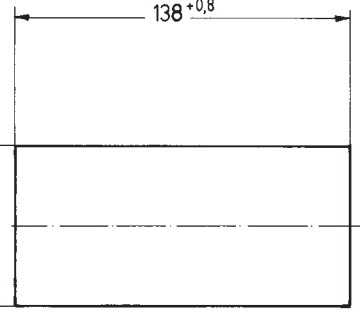

panel cut out

RECTANGULAR PANEL METERS

Rectangular Panel Meters

**Slim-line moving coil meters
direct current and direct voltage
accuracy class 1.5**

housing according to **DIN 43700**

Available housing types:



Pr 48 x 24

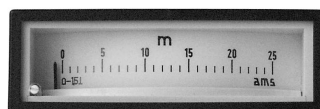

Pr 72 x 24

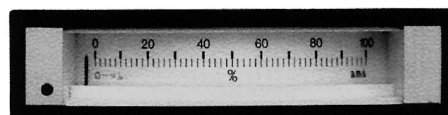

Pr 96 x 24/W

scale changeable from front

	Pr 48 x 24	Pr 72 x 24	Pr 96 x 24
Front frame	48 x 24 mm	72 x 24 mm	96 x 24 mm
Scale length approx.	32 mm	48 mm	60 mm
Weight approx.	0.08 kg	0.1 kg	0.15 kg

Movement	moving coil with core magnet (immune to magnetic fields)
Bearing	pivot with spring-loaded jewel
Pointer	beam-type pointer
Mounting version	choose from horizontal or vertical mounting
Housing	polycarbonate
Front frame	black, grey on request

RECTANGULAR PANEL METERS

Measuring ranges	Ammeters			Internal resistance / ΔU			Voltmeters	
		Pr 48 x 24	Pr 72 x 24	Pr 48 x 24	Pr 72 x 24	Pr 96 x 24		
	50 μ A	4500 Ω	4500 Ω	4500 Ω	4500 Ω	4500 Ω	100 mV	} Ri approx. 1000 Ω /V
	100 μ A	3800 Ω	3800 Ω	3800 Ω	3800 Ω	3800 Ω	150 mV	
	150 μ A	3800 Ω	3800 Ω	3800 Ω	3800 Ω	3800 Ω	400 mV	
	250 μ A	1300 Ω	1300 Ω	1300 Ω	1300 Ω	1300 Ω	600 mV	
	400 μ A	1100 Ω	1100 Ω	1100 Ω	1100 Ω	1100 Ω	1 V	
	600 μ A	380 Ω	380 Ω	380 Ω	380 Ω	380 Ω	1.5 V	
	1 mA	70 Ω	70 Ω	70 Ω	70 Ω	70 Ω	2.5 V	
	1.5 mA	30 Ω	30 Ω	30 Ω	30 Ω	30 Ω	4 V	
	2.5 mA	13 Ω	13 Ω	13 Ω	13 Ω	13 Ω	6 V	
	4 mA	5 Ω	5 Ω	5 Ω	5 Ω	5 Ω	10 V	
	6 mA	5 Ω	5 Ω	5 Ω	5 Ω	5 Ω	15 V	
	10 mA	3 Ω	3 Ω	3 Ω	3 Ω	3 Ω	25 V	
	15 mA	2.8 Ω	2.8 Ω	2.8 Ω	2.8 Ω	2.8 Ω	40 V	
	20 mA	2.3 Ω	2.3 Ω	2.3 Ω	2.3 Ω	2.3 Ω	60 V	
	25-600 mA	60 mV	60 mV	60 mV	60 mV	60 mV	100 V	
	1 A	-	-	-	-	-	150 V	
	1.5 A	-	-	-	-	-	250 V	
	2.5 A	-	-	-	-	-	400 V	
	4 A	-	-	-	-	-	500 V	
	6 A	-	-	-	-	-		
	10 A	-	-	-	-	-		
x) for operation with a separate shunt	4 -20 A	120 Ω	120 Ω	120 Ω	120 Ω	120 Ω		
tolerance of the internal resistance $\pm 20\%$	60 mV x)	12 Ω	12 Ω	12 Ω	12 Ω	12 Ω		

Rectangular Panel Meters

Slim-line moving coil meters

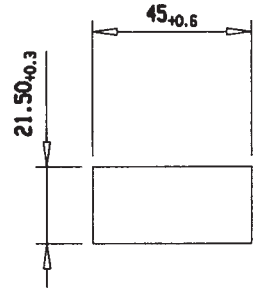
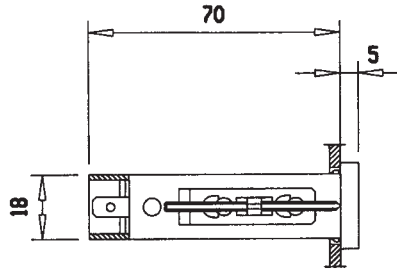
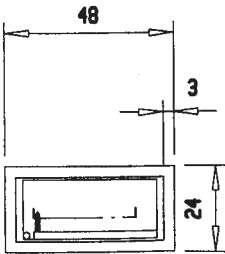

PR 48 x 24

Suitable for mosaic-grid mounting

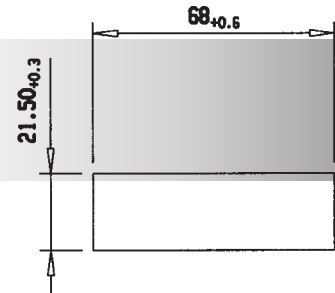
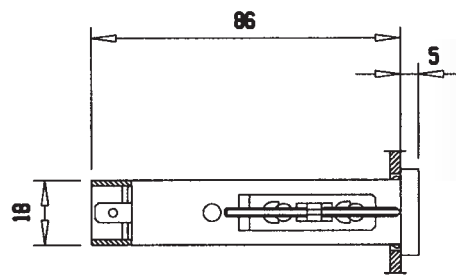
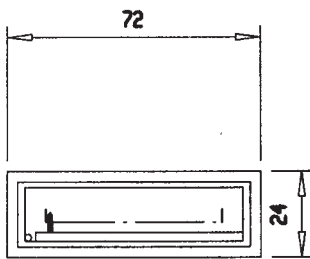

PR 72 x 24

Suitable for mosaic-grid mounting

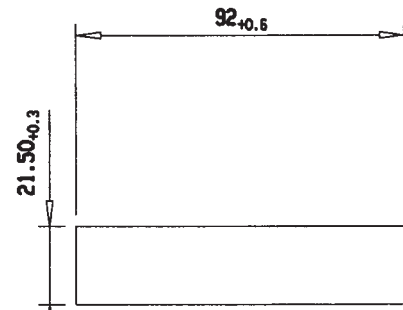
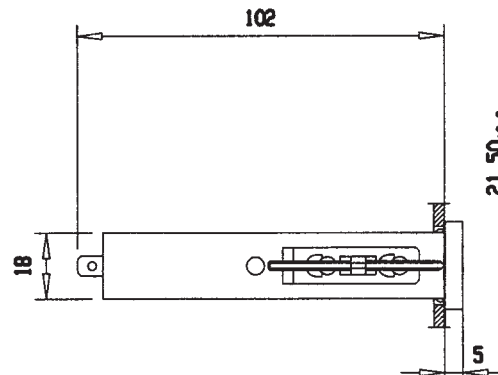
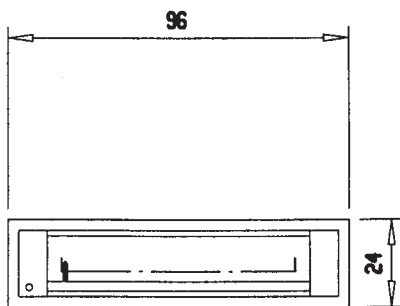

PR 96 x 24/W

Suitable for mosaic-grid mounting
Easy scale change from front

RECTANGULAR PANEL METERS

Rectangular Panel Meters

Special Designs

Edgewise Moving Coil Meters

Slim-Line Moving Coil Meters

Housing

Front frame colour	standard: black special colour: grey
Front glass	Pr 72 x 36, Pr 96 x 48, Pr 144 x 72 anti-glare glass
Scale illumination	Pr 96 x 24/W

Scales

Coloured scales	scale background black, scale division and numbering white or yellow coloured scale divisions or marks
Division	double division for Pr 72 x 36, Pr 96 x 48, Pr 144 x 72 calibration in different parameter than the measured electrical value

Movement

Internal resistance voltmeter	standard approx. 1000 Ω/V special versions: 2000 Ω/V 5000 Ω/V 10,000 Ω/V
Rectifier (for measuring AC)	voltmeter 6 - 600 V ammeter up to 20 mA built-in, from 1 to 20 A with separate current transformer n/0.01 A

Square Panel Meters

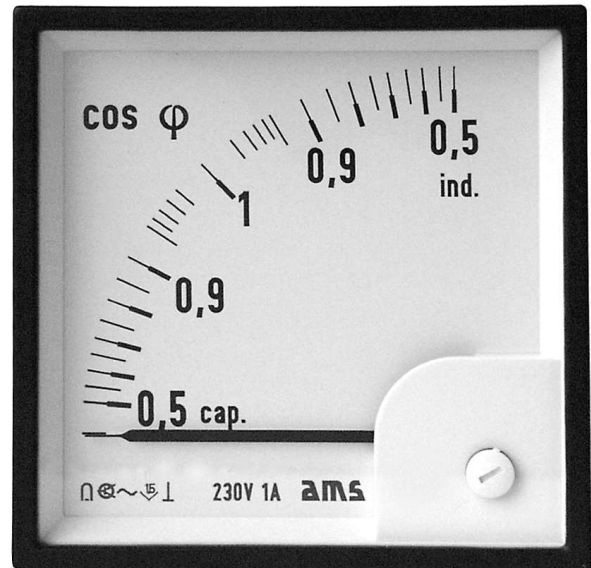
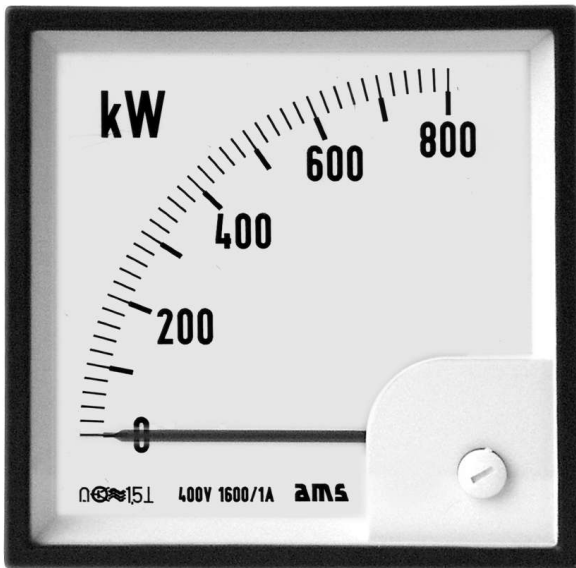

Active power meters Reactive power meters Power-factor meters

- Moving coil movement with power converter
- Power meter with staggered zero position for import and export
- Scale division for power meters almost linear

Square Panel Meters

Active power meters

Reactive power meters

Accuracy class 1.5

housing according to **DIN 43700**

Available housing types:

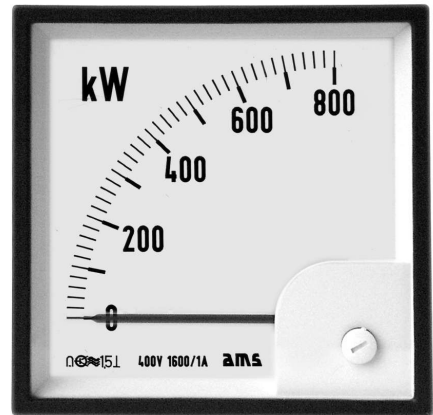
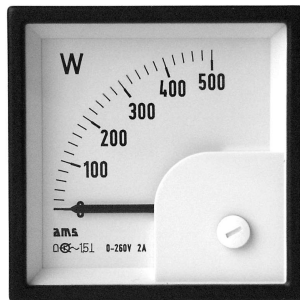

	DQ/E/W 72-R, DQ/E/W 72 R-2 DQ/E/W 72 R-1, DQ/E/W 72 R-3	DQ/E/W 96-R, DQ/E/W 96 R-2 DQ/E/W 96 R-1, DQ/E/W 96 R-3	DQ/E/W 144-R, DQ/E/W 144 R-2 DQ/E/W 144 R-1, DQ/E/W 144 R-3
Front frame	72 x 72 mm	96 x 96 mm	144 x 144 mm
Scale length approx.	62 mm	86 mm	140 mm
Weight approx.	0.3 kg/0.5 kg	0.3 kg/0.6 kg	0.8 kg/1.0 kg

SQUARE PANEL METERS

Movement

moving coil movement with power converter
scale 90°

Bearing

pivots with spring mounted jewel

Pointer

beam-type knife-edge pointer

Housing

polycarbonate, steel-sheet for size 144

Front frame

black, grey on request

Frequency range

45 ... 50 ... 60 Hz

Internal consumption

current path max. 0.5 VA

voltage path max. 4 VA

Type

DQ/E/W 72-R

single phase AC

100 V

1 A or

DQ/E/W 96-R

230 V

5 A

DQ/E/W 144-R

DQ/E/W 72 R-1

three-wire three-phase AC,
balanced load

100 V

1 A

DQ/E/W 96 R-1

230 V

or

DQ/E/W 144 R-1

400 V

5 A

DQ/E/W 72 R-2

three-wire three-phase AC,
unbalanced load

100 V

1 A

DQ/E/W 96 R-2

230 V

or

DQ/E/W 144 R-2

400 V

5 A

DQ/E/W 72 R-3

four-wire three-phase AC,
unbalanced load

57.8 / 100 V

1 A

DQ/E/W 96 R-3

127 / 220 V

or

DQ/E/W 144 R-3

230 / 400 V

5 A

Meters can be identified by '/W' for active power an '/B' for reactive power.

ams

Automatische Mess- und Steuerungstechnik GmbH 91275 Auerbach · Enge Gasse 1 91270 Auerbach · Postfach 1180

Phone +49 (0)96 43 / 92 05-0 Internet: www.ams-messtechnik.de
Fax +49 (0)96 43 / 92 05-90 e-mail: info@ams-messtechnik.de

Square Panel Meters

Power-factor meters Accuracy class 1.5

housing according to **DIN 43700**

Available housing types:

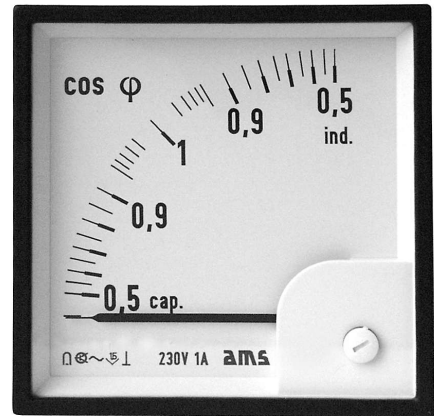
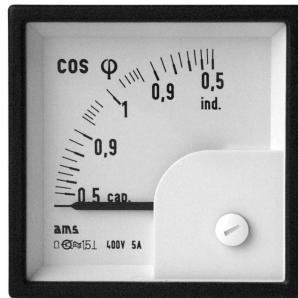

	CPhQ/E 72	CPhQ/E 96	CPhQ/E 144
Front frame	72 x 72 mm	96 x 96 mm	144 x 144 mm
Scale length approx.	64 mm	86 mm	140 mm
Weight approx.	0.5 kg	0.5 kg	1.0 kg

Movement

moving coil movement with power converter
scale 90°

Bearing

moving coil movement with power converter

Pointer

beam-type knife-edge pointer

Housing

polycarbonate, steel-sheet for size 144

Front frame

black, grey on request

Frequency range

50 ... 60 Hz

Internal consumption

current path approx. 1 VA
voltage path approx. 3 VA

Measuring range

CAP 0.5-1-0.5 IND

Power grid

single-phase AC,
balanced load

Nominal voltage

230 V

Nominal current

1 A or
5 A

CAP 0.5-1-0.5 IND

three-phase AC,
balanced load

100 V
230 V
400 V

1 A
or
5 A

SQUARE PANEL METERS

Square Panel Meters

Active power meters
Reactive power meters

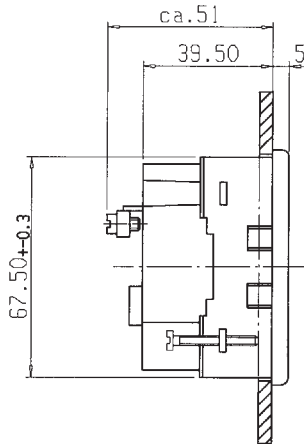
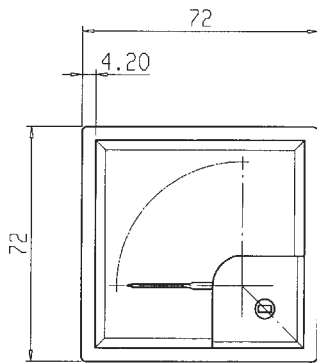

with additional separate
measuring accessory
91.3 x 91.3 x 43.6 mm

DQ/E/W 72

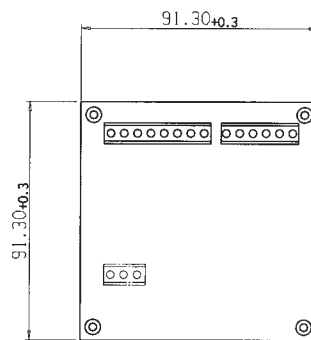
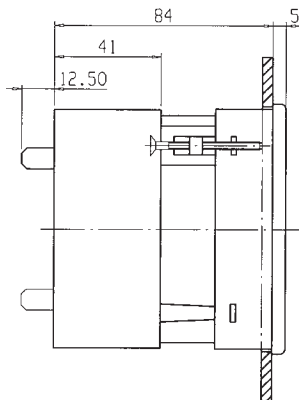
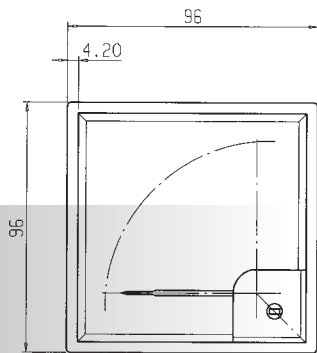

DQ/E/W 96

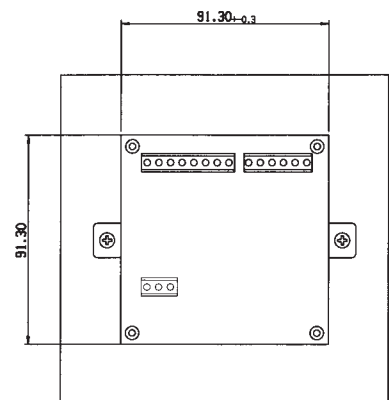
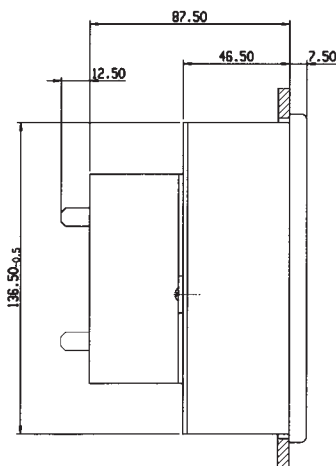
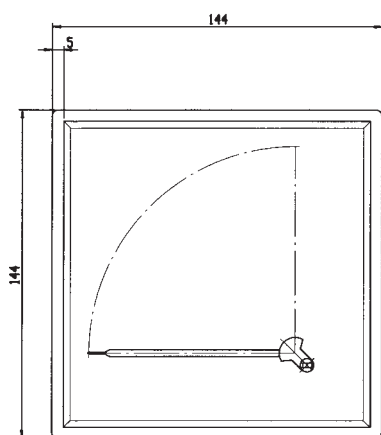

DQ/E/W 144

SQUARE PANEL METERS

Square Panel Meters

Active power meters Reactive power meters

Circuit diagrams

single-phase AC,
active or reactive power

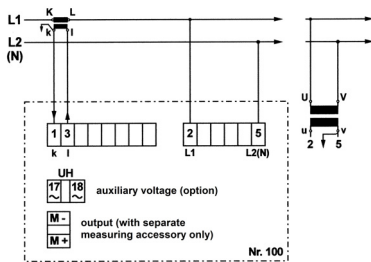

three-wire three-phase AC, balanced load,
active power

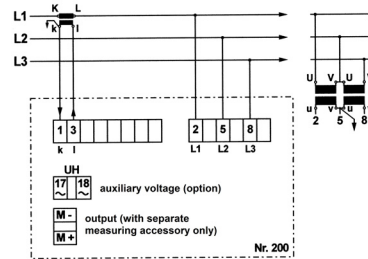

four-wire three-phase AC, balanced load,
active power

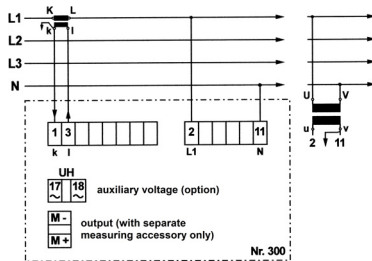

three-/four-wire three-phase AC, balanced load,
reactive power

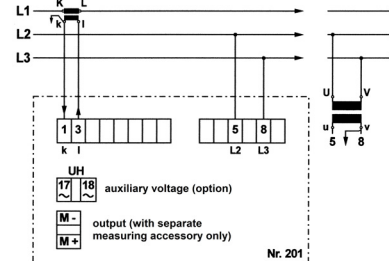

three-wire three-phase AC, any load,
active or reactive power

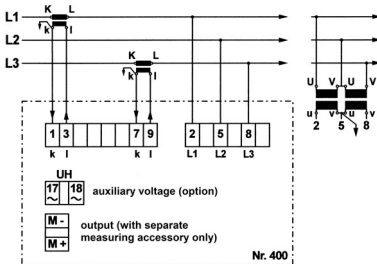

four-wire three-phase AC, any load,
active or reactive power

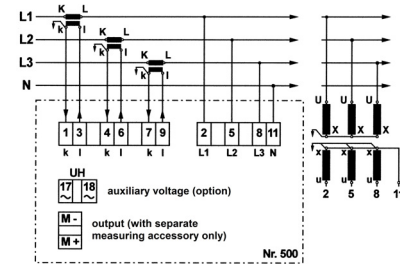

Important notice:

- Option: auxiliary voltage (UH) only necessary if nominal voltage fluctuates more than $\pm 20\%$
- Option: output (M-, M+) with separate measuring accessory only

Attention: no galvanic separation to the voltage inputs!

Power-factor meter

connection to single-phase AC

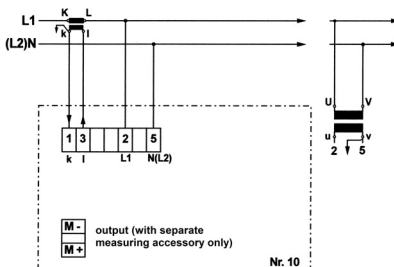

connection to three-wire three-phase AC, balanced load

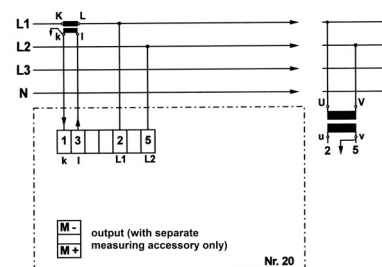

Operating Hours Counter for AC voltage

Available housing types:



BWQ 48

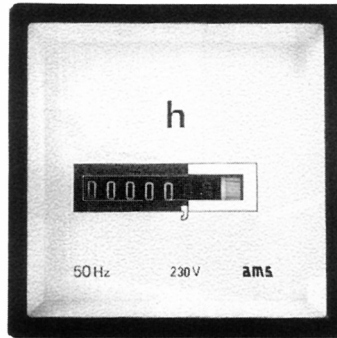

BWQ 72

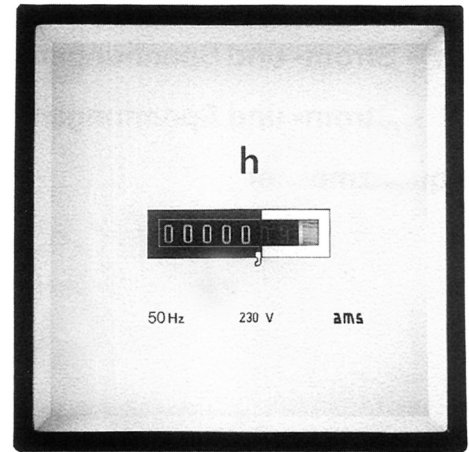

BWQ 96

	BWQ 48	BWQ 72	BWQ 96
Front frame	48 x 48 mm	72 x 72 mm	96 x 96 mm
Weight approx.	0.05 kg	0.2 kg	0.25 kg

**Counter
Housing**

99999.99 h
polycarbonate casing, self-extinguishing and drip-proof

**Front frame colour
Nominal voltages**

black, grey on request
230 V/AC
option: 110 V, 400 V/AC

Scale drawing

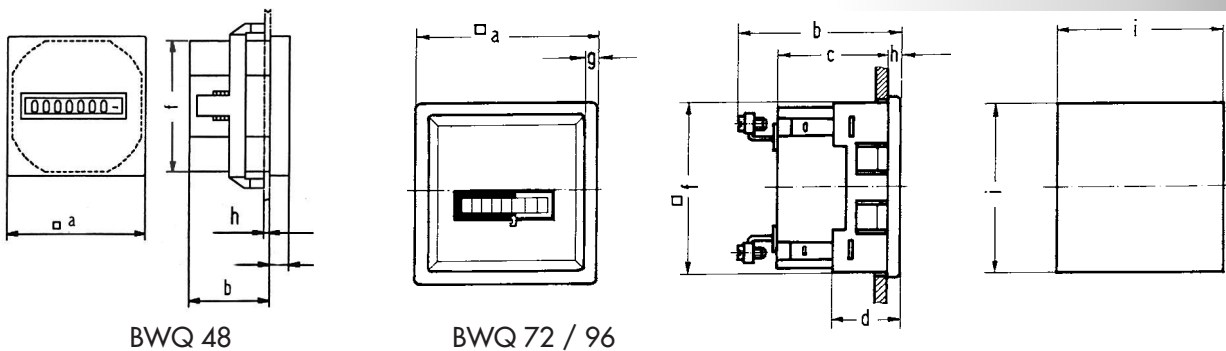

BWQ 48

BWQ 72 / 96

Dimensions in mm

name	a	b	c	d	f	g	h	panel cut-out
BWQ 48	□ 48	28			□ 44.7 ± 0.3		7	45 + 0.6
BWQ 72	□ 72	65	44	27	□ 67.5 ± 0.3	4.2	5	68 + 0.5
BWQ 96	□ 96	65	44	27	□ 91.3 ± 0.3	4.2	5	92 + 0.6

SPECIAL METERS

DIN Rail Meters

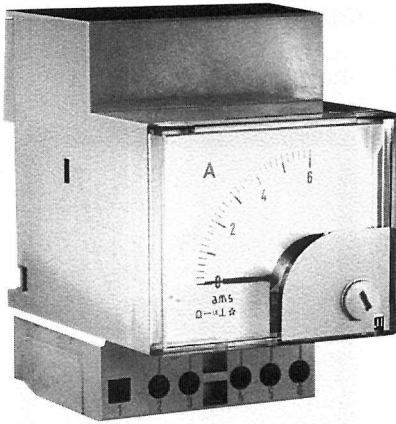

Meters to be mounted on 35 mm DIN rails, EN 50022

Moving iron - ammeters and voltmeters
Moving coil - ammeters and voltmeters
Pointer frequency meter

Available Types:

	H 45 DE	H 45 DS	H 45 Z
Movement	moving iron	moving coil	pointer frequency
Type of current	AC	DC	frequency
Accuracy class	1.5	1.5	0.5
Scale length approx.	40 mm	40 mm	40 mm
Weight approx.	0.15 kg	0.15 kg	0.15 kg

Measuring ranges

moving iron ammeters

100/ 200 mA
to 600/1200 mA
1/ 2 A
to 10/ 20 A
n/ 5 A connected to
n/ 1 A current transformer

voltmeters

10 V
to 500 V
n/100 V voltage transformer

moving coil ammeters

100 μ A
to 600 μ A
1 mA
to 20 mA
4 - 20 mA
1 A
to 10 A
60 mV shunt connection
150 mV shunt connection

voltmeters

100 mV
to 600 mV
1 V
to 500 V

frequency range

45 - 50 - 55 Hz
55 - 60 - 65 Hz

nominal voltage

110 V, 230 V
or 400 V

DIN Rail Meters

Moving iron - ammeters and voltmeters
 Moving coil - ammeters and voltmeters
 Pointer frequency meter

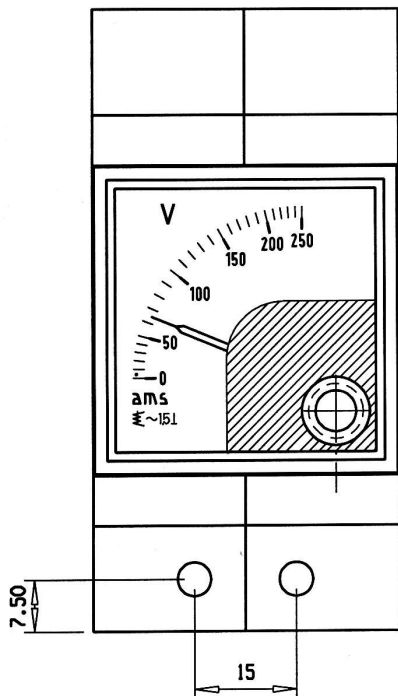
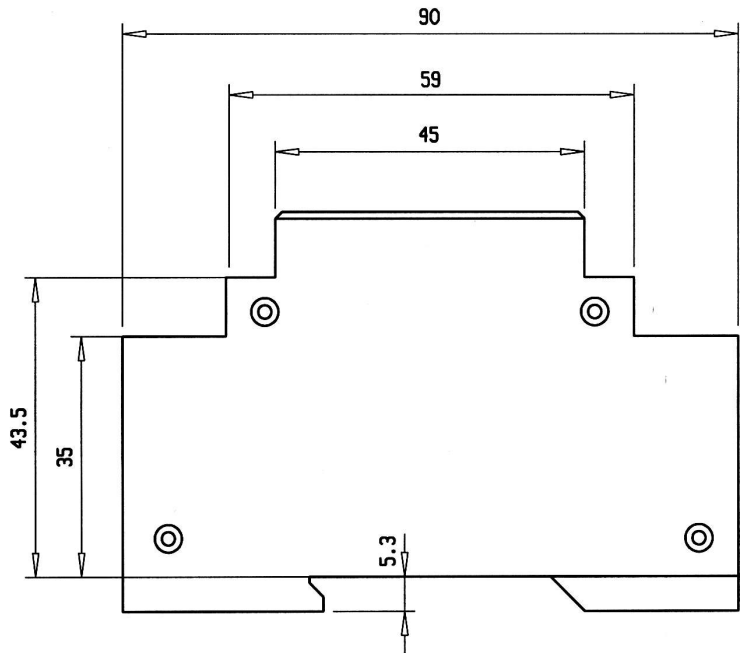
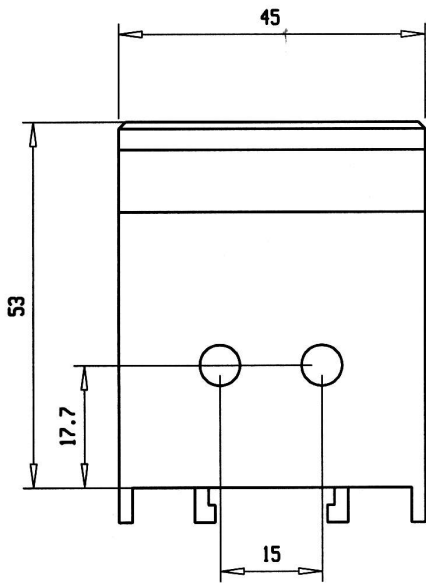

SPECIAL METERS

Switch Position Indicators for direct current or alternating current 45 ... 65 Hz

Specifications

Front frame black

front dimensions	25 x 25	Ø 25	Ø 32 ¹⁾
type	Stg 1	St 1	St 2
weight kg approx.	0.07	0.07	0.07
nominal insulation voltage	250 V	250 V	250 V
protection of front side	IP 52	IP 52	IP 52
fixing	ring nut	ring nut	ring nut

¹⁾ comes with plug-on type front frame (36 x 36 mm)

Connection voltage

direct current

24 V (0.3 W)
60 V (0.4 W)
110 V (0.6 W)
220 V (1.0 W)

alternating current 45 ... 65 Hz

24 V (0.3 VA)
60 V (0.4 VA)
110 V (0.6 VA)
220 V (1.2 VA)

Description

Switch position indicators for electrical remote indication of switch positions in plants and switching stations. Furthermore they can be used as target indicators in mimic diagrams.

Display

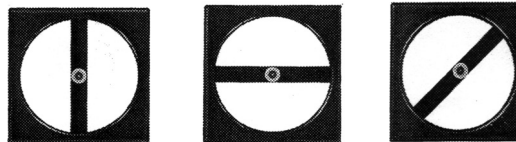

The display can show the following three states: "on", "off" and "error" or "disabled".

Mechanical Setup

housing material

polycarbonate, self-extinguishing (UL 94 V-2)

connection terminals

flat plug 2.8 x 0.8 mm

finger contact protection

available as option

Basic dimensions

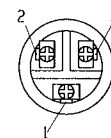
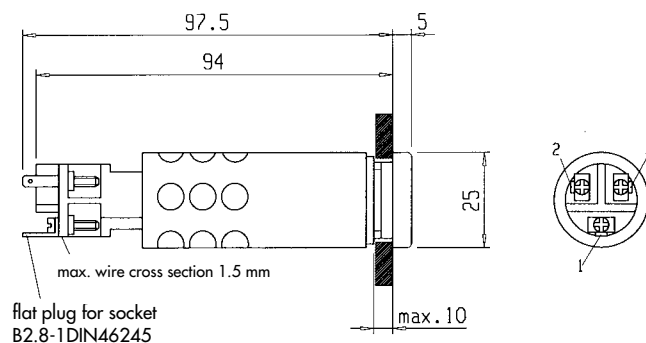

plug-on frame for front ring, diameter 32 mm

Front dimensions

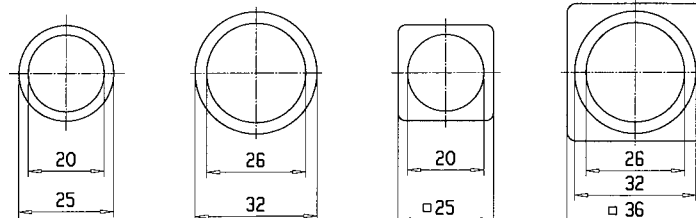

SPECIAL METERS

DIGITAL INSTRUMENTS

MFA-2001
Multifunctional display
Three-phase network measuring device

front frame
96 x 96 mm

Electricity meter EGZ
for alternating current and 3-phase current

Fitted digital meters M1 (48 x 24) for

front frame
48 x 24 mm

direct current

direct voltage

Fitted digital meters M1 (96 x 24) for

front frame
96 x 24 mm

direct current

direct voltage

direct voltage,
for shunt connection

Fitted digital meters M3 (96 x 24) for

sinusoidal alternating current

sinusoidal alternating voltage

Fitted digital meters M2 (96 x 48) for

front frame
96 x 48 mm

direct current

direct voltage

direct voltage,
for shunt connection

Fitted digital meters M3 (96 x 48) for

sinusoidal alternating current

sinusoidal alternating current

DIGITAL INSTRUMENTS

MFA-2001

Multifunctional display

Three-phase network measuring device

The **MFA-2001** is an electronic universal measuring device to meter and monitor all important measured values in a three-phase network.

It is applicable in all sectors from industry to trade.

By means of plainest parameterization and a clear operational guidance, every operator can adjust the depiction of the measured values individually, according to their requests and requirements.

There is a pulse output, furthermore an optional analogue output as well as a bus interface available to monitor and process the measured values.

The LC-Display with **background lighting** enables a reliable and non-reflecting reading even from a longer distance.



DIGITAL INSTRUMENTS

NEW!

WITH INTEGRATED OPERATING HOURS COUNTER

Measuring of

voltage	U, U_{\min}	$U_{L1-N}/U_{L2-N}/U_{L3-N}$ $U_{L1-L2}/U_{L2-L3}/U_{L3-L1}$
current	$I, I_{\text{avg}}, I_{\text{max}}$	$I_{L1}/I_{L2}/I_{L3}$
active power	$P, P_{\text{Mavg}}, P_{\text{max}}$	P_{Σ} $P_{L1}/P_{L2}/P_{L3}$
reactive power	$Q, Q_{\text{avg}}, Q_{\text{max}}$	Q_{Σ} $Q_{L1}/Q_{L2}/Q_{L3}$
power factor	$\cos \varphi$	$\cos \varphi_{\Sigma} / \cos \varphi_{\Sigma \text{Mittel}}$ $\cos \varphi_{L1} / \cos \varphi_{L2} / \cos \varphi_{L3}$
network frequency	f_{network}	$f_{L1}/f_{L2}/f_{L3}$
and	operating hours counter	h
or	active energy meter, procurement	kWh
or	reactive energy meter	kvarh

MFA-2001

Multifunctional Display

Three-phase grid meter

Further characteristics

- minimum - maximum storage for all relevant values
- displaying of the averaged current and the averaged maximum current (bimetal- / slave pointer function) adjustable integrating time
- current transformer connection 1 A or 5 A adjustable transformer ratio
- all values directly displayed with unit
- 2 limit value outputs or freely choosable 1 pulse output / 1 limit value output, limit value evaluating for all measured values freely choosable, pulse output for active energy
- quick and safe connection by means of screw terminals
- no separate power supply necessary

Specifications

frontal dimensions	96 x 96 mm	
protection class	IP 52 front side IP 65 (optional)	
operating temperature	- 10°C+ 55°C	
voltage input	340 – 475 V	phase - phase
	196 – 275 V	phase - neutral
current input	05 A (1 A)	
frequency	45 – 65 Hz	

Options

- RS-485 interface including readout software for PC
- interface converter RS 232 / RS 485
- interface converter USB / RS 485
- Profibus DP - V0
- analogue output 0/4-20 mA
- power supply 230 V AC
- power supply 24 V DC
- direct input 3 x 30(50) Ampere AC
- mounting support for DIN rails

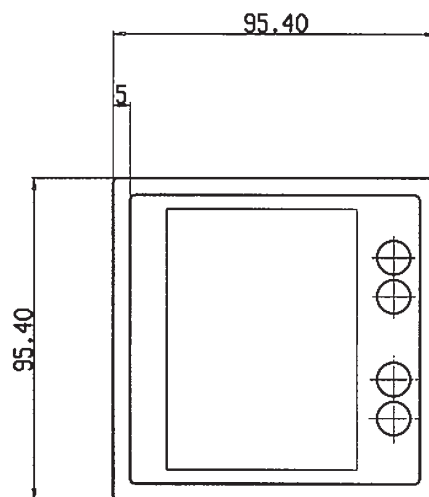

Scale drawing

Dimensional changes reserved!

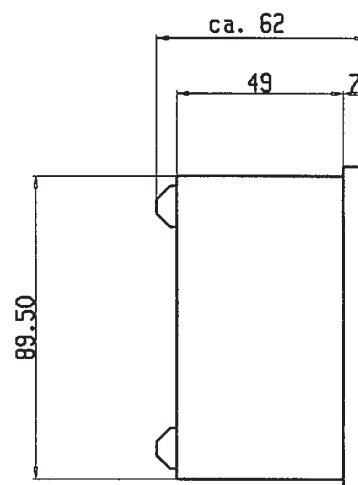

DIGITAL METERS

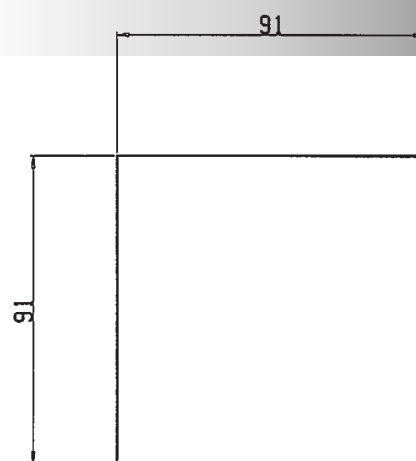

panel cut-out

Electricity Meter EGZ for single-phase or three-phase AC

The electronic electricity meter is used to gather the active energy for import and export in single-phase and three-phase AC networks. The device is available as a version with transducer connection or with direct connection. The compact and simply operable electricity meter takes the liberty of its operation in any places, like industrial systems, machine shops, offices etc.

The values measured by the electricity meters are indicated directly by means of a two-lines LC-display and additionally recorded in a data memory.

The electricity meters have two pulse outputs to transmit the measured values for import and export. Additionally, the instantaneous active power can be displayed by means of an analogue output.

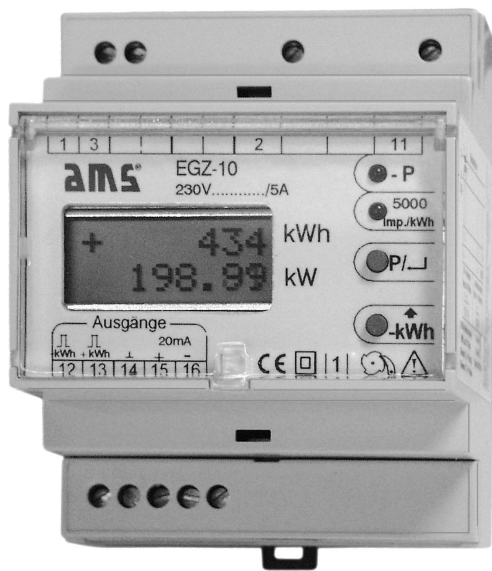

EGZ-10
electricity meter
for single-phase AC

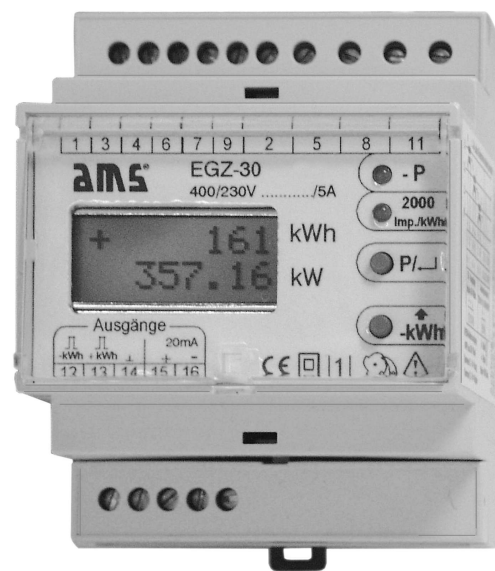

EGZ-30
electricity meter
for three-phase AC
3- and 4-wire, any load

DIGITAL INSTRUMENTS

Special features of the **electricity meter EGZ:**

- Available for three-phase AC (three and four wire network) and for single-phase AC.
- Adjustable transformer ratio
- Accuracy class 1
- Two-lines LC-Display
- LEDs for functional check
- Resettable kWh-counter
- Pulse output for active energy (import and export)
- Analogue output 0/4-20 mA for active energy
- Direct connection by means of through-hole apertures, max. 63 A (optional)

Electricity Meter EGZ for alternating current and 3-phase current

Type	EGZ-10	EGZ-30
Application	Electricity meter for active energy (import and export)	
	for alternating current	for 3-phase current
Double-spaced LC display	active energy (import) +9 999 999 kWh instantaneous active power, 9 999.99 kW, with (-) for negative power	
Functional displays	LED for active power LED for energy flow direction (-P) and phase angles $\geq 90^\circ$	
Input		
Nominal voltage	230 V +/- 20%	400/230 V AC and 3 x 400 V AC +/- 20%
Nominal current	0-5 A, option 0-1 A, 40 primary currents choosable via front button (5/5 A ... 4000/5A)	
Nominal frequency	50 - 60 Hz	
Internal consumption	voltage path approx. 0.1 VA (between L1 and L2/N: 2.5 VA), current path approx. 0.5 VA	
Permanent overload	voltage and current 1.2-fold, direct connection: current 6.3-fold	
Shock overload	voltage 2-fold 1 sec., current 20-fold, 0.5 sec., direct connection: current 30-fold, 10 ms	
Temperature range	-15° C to + 55° C	
Pulse output		
Active energy, import and export	transistor, 24 V DC (max. 30 V), on (active) 10-27 mA, off (inactive) < 1 mA	
Significance	1/10/100/1000/2000 or 5000 pulses/kWh, choosable via front button	
Accuracy	+/- 1 %	
Pulswidth	60 - 100 ms	
Separation	4 kV test voltage, 50 Hz, 10 sec.	
Analogue output		
Nominal value, with current transducer	0/4-20 mA corresponds to 0-1150 W at 5/5 A	0/4-20 mA corresponds to 0-3450 W at 5/5 A
Nominal value, direct connection	0/4-20 mA corresponds to 0-13,5 kW	0/4-20 mA corresponds to 0-40 kW
Accuracy	+/- 0.5 %	
Load resistance	0-500 Ohm	
Time lag	< 1 sec.	
Separation	4 kV test voltage, 50 Hz, 10 sec.	
Reset		
Zeroing	the zeroing of the kWh display can be done by means of front buttons	
Instructions		
EMV	DIN EN 61 326	
Mechanical firmness	DIN EN 61 010 Part 1	
Electric safety	DIN EN 61 010 Part 1, housing safety insulated, contamination level 2, measurement category CAT III	
Pulse output	DIN SO 43 864	
Accuracy / overload	DIN EN 60 688	
Clearances and creepage distances	DIN EN 61 010 Part 1	
Protection category	DIN EN 60 529, IP 20	
Weight		
	approx. 220 g	approx. 220 g
Installation		
Mounting	snap-in mounting on DIN rail according to DIN EN 50 022	
Electrical connection	screw connection max. 4 mm ²	
Dimensions		
(HxWxD) in mm	90 x 71 x 73	90 x 71 x 73

Subject to change!

DIGITAL METERS

Fitted Digital Meters M1 (48 x 24)

Front frame
48 x 24 mm



Technical data:

Measurement device	4 digits, max. 9999
Display	LED red, 10 mm (optionally green, blue or orange); freely programmable
Inputs	galvanically isolated from the supply
Accuracy	0.2 % of full range, ± 1 digit
Power supply	24 V DC $\pm 10\%$, max. 1 VA
Decimal point	programmable
Measurement time	0.1 10 seconds
Protection category	IP65 at the front

Direct currents:

ranges	Ri
0 - 20 mA	approx. 100 Ω
4 - 20 mA	approx. 100 Ω

ranges: 20, 100, 200 A
with external shunts (accessory)

Direct voltages:

ranges	Ri
60 mV	approx. 12 k Ω
150 mV	approx. 30 k Ω
± 10 V	approx. 200 k Ω

indication, deviating from the input signal on demand

Further measurement inputs on demand:
resistance, PT100, PT1000 and thermocouples

Mechanical dimensions: cut out dimensions: 45.0^{+0.8} x 22.0^{+0.6} mm

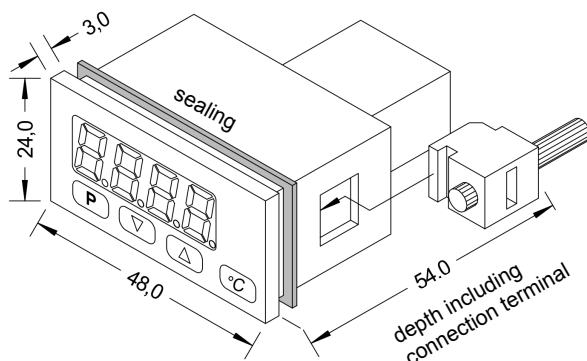

Fitted Digital Meters M1 (96 x 24)

Front frame
96 x 24 mm



Technical data:

Measurement device	4 digits, max. 9999
Display	LED red, 14 mm (optionally green, blue or orange)
Inputs	galvanically isolated from the supply
Accuracy	0.2 % of full range, ± 1 digit
Power supply	24 V DC $\pm 10\%$, max. 1 VA or 230 V AC $\pm 10\%$ / 6 VA
Decimal point	programmable
Measurement time	0.1 10 seconds
Protection category	IP65 at the front

Direct currents:

ranges	Ri
0 - 20 mA	approx. 100 Ω
4 - 20 mA	approx. 100 Ω

Direct voltages:

range	Ri
± 10 V	approx. 200 k Ω

Direct voltage, for shunt connection

ranges	Ri
60 mV	approx. 12 k Ω
150 mV	approx. 30 k Ω

Further measurement inputs on demand:
resistance, PT100, PT1000 and thermocouples

DIGITAL INSTRUMENTS

Mechanical dimensions: cut out dimensions: $92.0^{+0.8} \times 22.2^{+0.3}$ mm

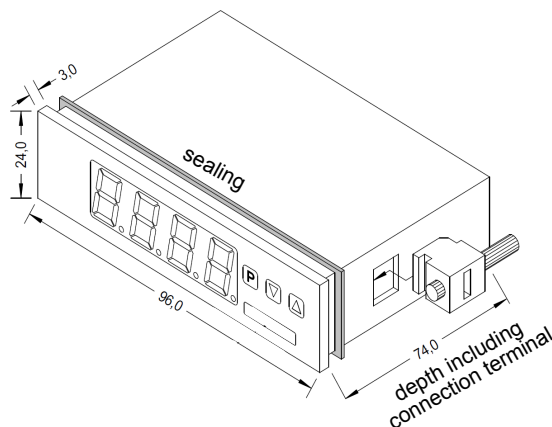

Fitted Digital Meters M3 (96 x 24)

Front frame
96 x 24 mm



Technical data:

Measurement device	5 digits, max. 99999
Display	LED red, 14 mm (optionally green, blue, orange or tricolour)
Inputs	galvanically isolated from the supply
Accuracy	0.5 % of full range
Power supply	10 - 30 V DC, max. 4 VA or 100 - 240 V AC/DC $\pm 10\%$, max. 10 VA
Decimal point	programmable
Measurement time	0.1 10 seconds
Protection category	IP65 at the front

Alternating currents sinusoidal

ranges	Ri
1 A	approx. 0.2 Ω
5 A	approx. 0.05 Ω

Direct voltage, sinusoidal

ranges	Ri
10 V	approx. 40 k Ω
50 V	approx. 200 k Ω
600 V	approx. 2 M Ω

Further measurement inputs on demand:
resistance, PT100, PT1000 and thermocouples

Mechanical dimensions: cut out dimensions: 92.0^{+0.8} x 22.2^{+0.3} mm

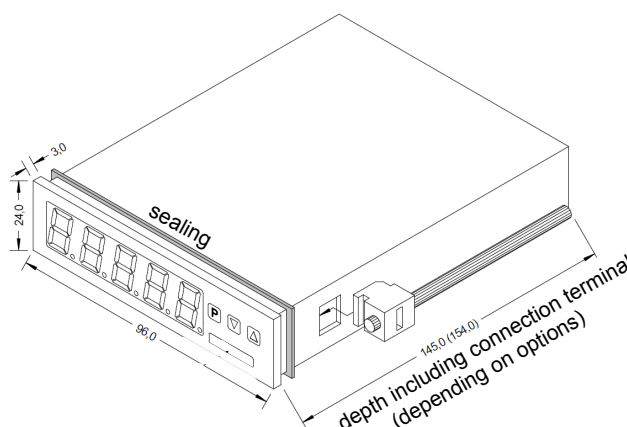

Fitted Digital Meters M2 (96 x 48)

Front frame
96 x 48 mm



Technical data:

Measurement device	5 digits, max. 99999
Display	LED red, 14 mm (optionally green, blue, orange or tricolour)
Inputs	galvanically isolated from the supply
Accuracy	0.5 % of full range
Power supply	10 - 30 V DC, max. 4 VA or 230 V AC $\pm 10\%$, max. 10 VA
Decimal point	programmable
Measurement time	0.1 10 seconds
Protection category	IP65 at the front

Direct current:

ranges	Ri
0 - 20 mA	approx. 100 Ω
4 - 20 mA	approx. 100 Ω
0 - 1 A	approx. 0.2 Ω

Direct voltage:

ranges	Ri
± 10 V	approx. 200 k Ω
± 50 V	approx. 200 k Ω
± 300 V	approx. 1 M Ω
± 600 V	approx. 2 M Ω

Direct voltage, for shunt connection:

ranges	Ri
60 mV	approx. 12 k Ω
150 mV	approx. 60 k Ω
300 mV	approx. 30 k Ω

Further measurement inputs on demand:
resistance, PT100, PT1000 and thermocouples

Mechanical dimensions: cut out dimensions: 92.0^{+0.8} x 45.0^{+0.6} mm

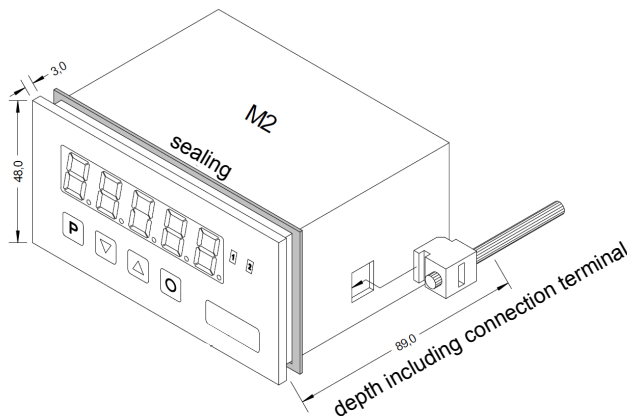

Fitted Digital Meters M3 (96 x 48)

Front frame
96 x 48 mm



Technical data:

Measurement device	5 digits, max. 99999
Display	LED red, 14 mm (optionally green, blue, orange or tricolour)
Inputs	galvanically isolated from the supply
Accuracy	0.5 % of full range
Power supply	10 - 30 V DC, max. 8 VA or 230 V AC $\pm 10\%$, max. 20 VA
Decimal point	programmable
Measurement time	0.1 10 seconds
Protection category	IP65 at the front

Alternating currents sinusoidal

ranges	Ri
1 A	approx. 0.2 Ω
5 A	approx. 0.05 Ω

Alternating voltages sinusoidal

ranges	Ri
10 V	approx. 40 k Ω
50 V	approx. 200 k Ω
300 V	approx. 1 M Ω
600 V	approx. 2 M Ω

Further measurement inputs on demand:
resistance, PT100, PT1000 and thermocouples

Mechanical dimensions: cut out dimensions: 92.0^{+0.8} x 45.0^{+0.6} mm

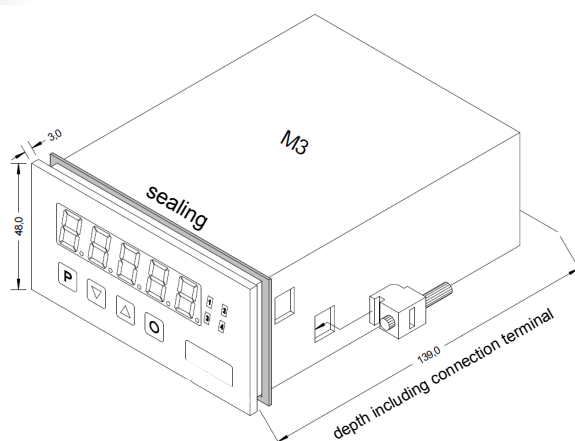

Shunts DIN 43703 Class 0.5

Shunt base (two-piece)



Shunt base (one-piece)

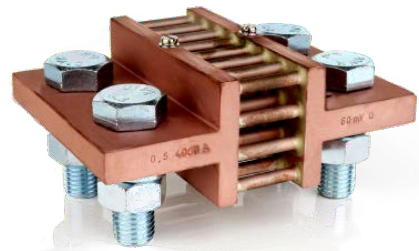
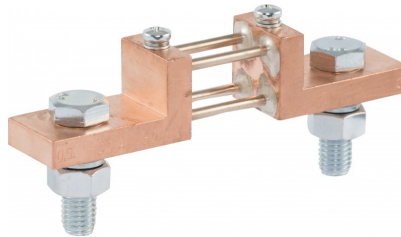
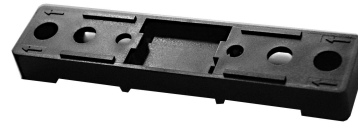

Type A			Type B			Type C			
nominal current [A]	voltage drop	approx. weight [kg]	nominal current [A]	voltage drop	approx. weight [kg]	nominal current [A]	voltage drop	approx. weight [kg]	
1	60 mV 100 mV 150 mV or 300 mV	0.10	250	60 mV 100 mV 150 mV or 300 mV	0.5	4000	60 mV 100 mV 150 mV or 300 mV	4.3	
1.5		0.10							
2.5		0.10	400			0.8		6000	10.9
4		0.10							
6		0.10	600			0.8		10000	21.1
10		0.10							
15		0.11	1000			1.4		15000	31.7
25		0.11							
40		0.12	1500			2.0			
60		0.13							
80		0.13	2500			2.9			
100		0.13							
120		0.13							
150		0.13							
200		0.13							

The weight specifications apply for shunts with 60 mV voltage drop.

Custom versions:

nominal current and voltage drop deviating from the above line,
custom shape and size

ACCESSORIES

Shunts DIN 43703

voltage drop [mV]	dimension [mm]	for nominal current [A]													
		1-25	30-250	300-400	200-350	400-800	900-1000	1000-1250	1500-2000	2500-3000	3000-5000	6000-8000	8000-10000	15000	
60		type A			type B						type C				
	a ₁	90	100		145			165			165	175	185		
	a ₂	28	33		55			65			65	70	75		
	b ₁	20		30	30	40	60		90	120	120	154	206	310	
	b ₂	-			15	20	30		21	30	30	25			
	b ₃	-			-				48	60	60	52			
	c ₁	8	10		10						15	25	30		
	c ₂	-			10						10	15	20		
	e	78	80		105			115			115	125	135		
h	-			30						60	130	170			
150		type A			type B				type C						
	a ₁	90	225		270		290		290		300		310		
	a ₂	28	33		55		65		65		70		75		
	b ₁	20	25		30	40	70		90	120	154	206	310		
	b ₂	-			15	20	35		21	30	25				
	b ₃	-			-				48	60	52				
	c ₁	8			10						15	25	30		
	c ₂	-			10						10	15	20		
	e	78	205		230		240		240		250		260		
h	-			50		60		60		130		170			
number of current connections	2 x 1						2 x 2			2 x 3	2 x 4	2 x 6			
hexagon screw DIN 933-5	M5 x 12	M8 x 15	M10 x 18	M12 x 40	M16 x 45	M20 x 50		M16 x 45	M20 x 50	M20 x 60	M20 x 75	M20 x 50			
washer DIN 125 ingot steel	5.3	8.4	10.5	13.5	17	21		17	21						
nut DIN 934-5	-	-	-	M12	M16	M20		M16	M20						
voltage connections	2 cross recessed head screws M5 x 8 DIN 84-4 and washers 5.3 DIN 433 ingot steel														

For more information please see our separate shunt brochure

Subject to change

ACCESSORIES

Dimensions in mm type A

type B

type C

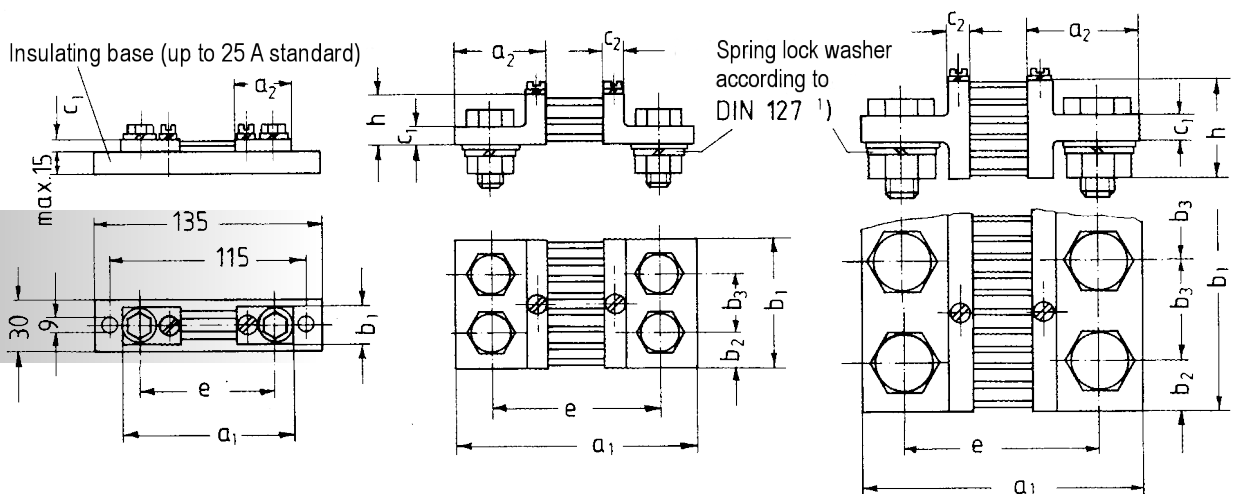

Wire resistance: by default the meter is calibrated for a wire resistance of 0.035 ohms.
For longer connecting wires please state wire resistance.

Insulating base: an insulating base is optionally available for shunts of type A from 40 A as well as for some current ranges of type B.

ASK, WSK and ASR Current Transformers

Current transformers are used to convert a high alternating current into a galvanically isolated alternating current of 5 A or 1 A.

All of our current transformers are produced according to DIN VDE 0414/1, DIN 42600 and DIN EN 60044/1 issue 11/2001 as well as the regulation VBG 4.

The product range includes plug-on current transformers, wound primary current transformers, summation current transformers and split core current transformers with a handy click-on lock.

The transformers are produced in class 1 or class 0.5 as a standard. Special versions are available in class 0.2 on demand.

Generally, the delivery of our transducers contains:

- primary conductor mounting
- insulation protective cap
- foot mounting
- secondary terminal cover

Table for secondary 5 A and 1 A, class 1, mostly also available in class 0.5 and certified.

type	ASK 231.5	ASK 31.3	ASK 31.4	ASK 31.5	ASK 41.4	ASK 51.4	ASK 61.4	ASK 63.6	ASK 81.4	ASK 101.4	ASK 103.3
1											
2.5											
5											
10											
15											
20											
25											
30											
40											
50			X	X							
60		X	X	X							
75		X	X	X	X						
80	X	X	X	X	X						
100	X	X	X	X	X	X					
125	X										
150	X	X	X	X	X	X					
200	X	X	X	X	X	X	X	X			
250	X	X	X	X	X	X	X	X			
300	X	X	X	X	X	X	X	X			
400	X	X	X	X	X	X	X	X	X		
500	X	X	X	X	X	X	X	X	X	X	
600		X	X	X	X	X	X	X	X	X	
750		X	X	X	X	X	X	X	X	X	X
800					X	X	X	X	X	X	X
1000					X	X	X	X	X	X	X
1200						X	X	X	X	X	X
1250							X	X	X	X	X
1500								X	X	X	X
1600								X	X	X	X
1800										X	X
2000									X	X	X
2500											X
3000											X
bus bar mm	30x10	30x10 2x20x10	30x10 2x20x10	30x10 2x20x10	40x10 2x30x5	50x12 2x40x10	60x10 2x50x10	60x30	80x10 2x60x10	100x10 2x80x10	2x100x10 3x80x10
conductor Ø mm	28	26	28	28	32	44	44	30	55	70	85
width mm	49.5	60	60	60	70	85	95	88	120	130	172

ACCESSORIES

Optionally the current transformers can be equipped with a snap-on fixing for mounting on a DIN-rail.

ASK, WSK and ASR Current Transformer

Table for secondary 5 A and 1 A, class 1,
mostly also available in class 0.5 and certified .

ACCESSORIES

type	ASK	ASK	ASK	ASR	ASR	WSK	WSK	WSK	KBU	KBU	KBU	KBU
primary current	105.6	127.6	130.5	22.3	201.3	30	40	60	23	58	812	816
1						X	X					
2.5						X	X					
5						X	X	X				
10						X	X	X				
15						X	X	X				
20						X	X	X				
25							X	X				
30							X	X				
40												
50												
60				X	X							
75				X	X							
80				X	X							
100				X	X				X			
125												
150				X	X				X			
200				X	X				X			
250				X	X				X	X	X	
300			X	X	X				X	X	X	
400			X	X					X	X	X	
500			X	X						X	X	
600	X		X	X						X	X	
750	X		X							X	X	
800	X		X							X	X	
1000	X	X	X							X	X	X
1200	X	X	X								X	X
1250	X	X	X								X	
1500	X	X	X								X	X
1600			X									X
1800	X	X										
2000	X	X	X									X
2500	X	X	X									X
3000	X	X	X									X
4000		X										
5000		X						70				
6000		X				60						
bus bar mm	100x55	120x72	130x30						30x20	50x80	80x120	80x160
conductor Ø mm	55	72		22.5	21		70					
width mm	128	205	180	60	44				58	58	58	79

Tube Current Transformer Type ASR 201.3

Circular conductor 21.0 mm Ø



primary nominal current A	nominal power for sec. 5 A	
	class 0.5 VA	class 1 VA
60		1
75; 80		1.5
100	1.5	2.5
125	1.5	2.5
150	1.5	3.75
200	2.5	2.5
		3.75
250	2.5	2.5
		5
300	2.5	2.5
		5

This current transformer corresponds to VDE 0414/1-3, DIN 42600 and IEC 185.

Unbreakable plastic housing, Macrolon black, self-extinguishing, low flammable, transformer housing ultrasonically welded.

Nominal frequency 50 Hz (also applicable at 60 Hz); insulation class E; overload factor M 5.

$I_{th} = 60 I_{1N}$ (I_{1N} for 1 s duration);

V_{max} 720 V 0.5 series

Secondary nominal current 5 A

Optional secondary nominal current 1 A

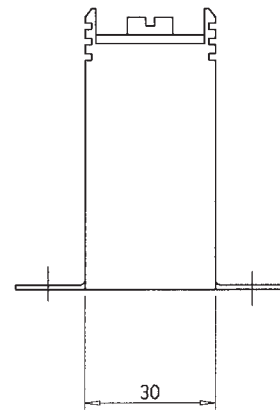
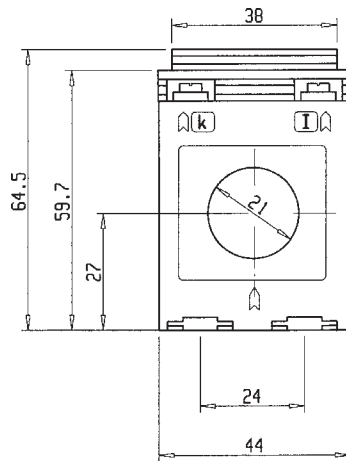

ACCESSORIES

Snap-on mounting for 35 mm DIN rail available

More transformer types on request

Tube Current Transformer Type ASR 22.3

Circular conductor 22.5 mm Ø



This current transformer corresponds to VDE 0414/1-3, DIN 42600 and IEC 185.

Unbreakable plastic housing, Macrolon black, self-extinguishing, low flammable. Transformer housing ultrasonically welded.

Nominal frequency 50 Hz (also applicable at 60 Hz);
Insulation class E;
Overload factor M5

$$I_{th} = 60 I_{1N} \text{ (} I_{1N} \text{ for 1 s duration)};$$

$$V_{max} \text{ 720 V} \quad \text{0.5 series}$$

Secondary nominal current 5 A
Optional secondary nominal current 1 A

primary nominal current A	nominal power for sec. 5 A		
	class 0.5 VA	class 1 VA	
60		1.5	
75; 80		1.5	
100	2.5	2.5	
150	2.5	2.5	
		5	
200	2.5	2.5	
		5	
250	2.5	2.5	
		5	5
			10
300	2.5	2.5	
		5	5
			10
400	2.5	2.5	
		5	5
500	2.5		2.5
		5	5
			10
600	5	5	
		10	

ACCESSORIES

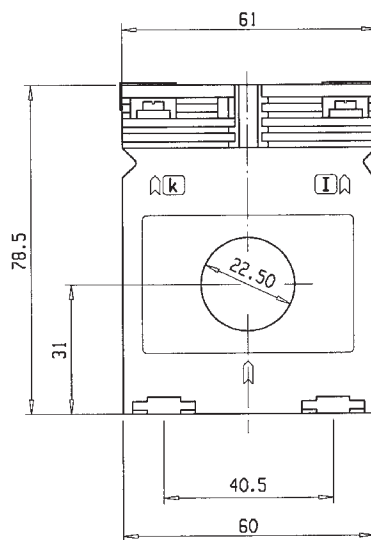

Standard foot mounting
with terminal cover

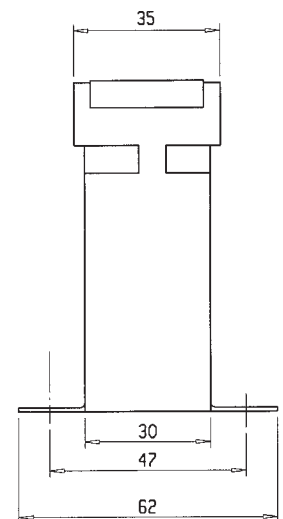

Snap-on mounting for 35 mm DIN rail available

More transformer types on request

Tube Current Transformer Type ASR 231.5

Primary conductor 30 x 10 mm
Circular conductor 28.0 mm Ø



primary nominal current A	nominal power for sec. 5 A	
	class 0.5 VA	class 1 VA
80		1.25
100		1.5
125		2.5
150		2.5
200	2.5	2.5
250	2.5	2.5
300	2.5	2.5
400	2.5	5
500	5	5
	2.5	2.5
	5	5

This current transformer corresponds to VDE 0414/1-3 DIN 42600 and IEC 185.

Unbreakable plastic housing, Macrolon black, self-extinguishing, low flammable, transformer housing ultrasonically welded.

Nominal frequency 50 Hz (also applicable at 60 Hz); insulation class E; overload factor M 5.

$$I_{th} = 60 I_{1N} \text{ (} I_{1N} \text{ for 1 s duration) ;}$$

$$V_{max} 720 \text{ V} \quad 0.5 \text{ series}$$

Secondary nominal current 5 A

Optional secondary nominal current 1 A

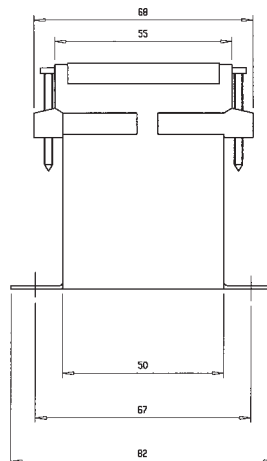
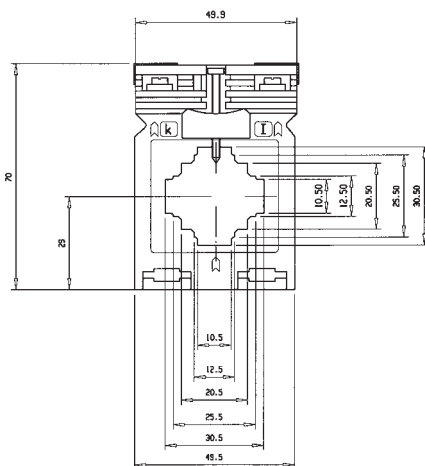

Standard foot mounting with terminal cover

More transformer types on request

ACCESSORIES

Plug-on Current Transformer Type ASK 31.3



Primary conductor 30 x 10 mm

Circular conductor 28.0 mm Ø

This current transformer corresponds to VDE 0414/1-3, DIN 42600 and IEC 185.

Unbreakable plastic housing, Macrolon black, self-extinguishing, low flammable. Transformer housing ultrasonically welded.

Nominal frequency 50 Hz (also applicable at 60 Hz);
Insulation class E;
Overload factor M 5

$$I_{th} = 60 I_{1N} \text{ (} I_{1N} \text{ for 1 s duration)};$$

$$V_{max} 720 \text{ V} \quad 0.5 \text{ series}$$

Secondary nominal current 5 A

Optional secondary nominal current 1 A

primary nominal current A	nominal power for sec. 5 A	
	class 0.5 VA	class 1 VA
60		1
75; 80		1.5
100	2.5	2.5
150	2.5	2.5
200	2.5	2.5
		5
250	2.5	2.5
	5	5
300	2.5	2.5
	5	5
		10
400	2.5	2.5
	5	5
		10
500	2.5	2.5
	5	5
	10	10
600	5	5
	10	10

ACCESSORIES

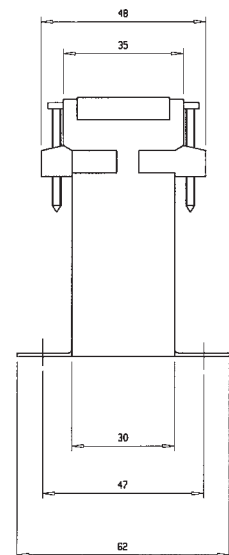
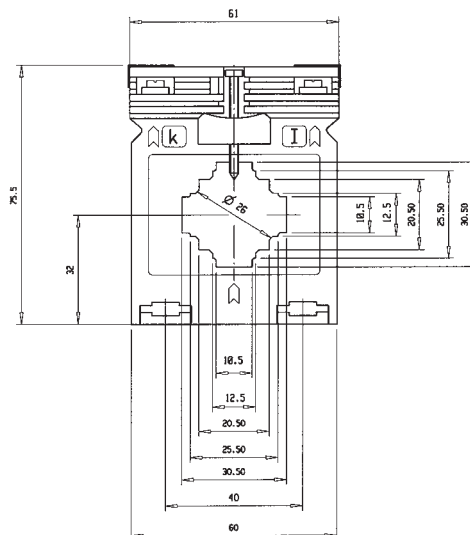

Standard foot mounting with terminal cover

Snap-on mounting for 35 mm DIN rail available

More transformer types on request

Plug-on Current Transformer Type ASK 31.4

Primary conductor 30 x 10 mm
Circular conductor 28.0 mm Ø



This current transformer corresponds to VDE 0414/1-3, DIN 42600 and IEC 185.

primary nominal current A	nominal power for sec. 5 A	
	class 0.5 VA	class 1 VA
50; 60		1.25
75; 80		1.5
100		2.5
	2.5	3.75
150	2.5	2.5
		5
200	2.5	2.5
	5	5
250	2.5	2.5
	5	5
		10
300	2.5	2.5
	5	5
	10	10
400	2.5	2.5
	5	5
	10	10
500	2.5	2.5
	5	5
	10	10
600	5	5
	10	10
	15	15
750	5	5
	10	10
	15	15

Secondary nominal current 5 A
Optional secondary nominal current 1 A

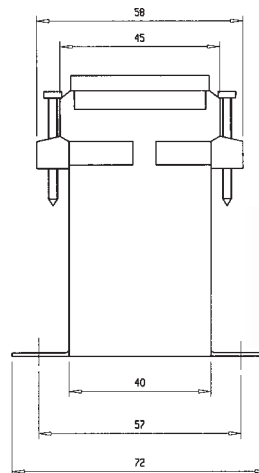
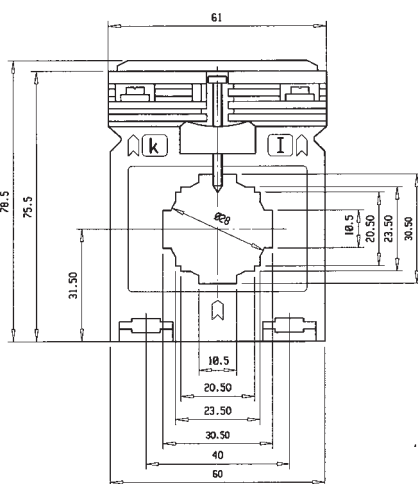

Standard foot mounting
with terminal cover

Snap-on mounting for 35 mm DIN rail available

More transformer types on request

ACCESSORIES

Plug-on Current Transformer Type ASK 31.5



Primary conductor 30 x 10 mm

Circular conductor 28.0 mm Ø

This current transformer corresponds to VDE 0414/1-3, DIN 42600 and IEC 185.

Unbreakable plastic housing, Macrolon black, self-extinguishing, low flammable. Transformer housing ultrasonically welded.

Nominal frequency 50 Hz (also applicable at 60 Hz);
Insulation class E;
Overload factor M 5

$$I_{th} = 60 I_{1N} \text{ (} I_{1N} \text{ for 1 s duration)};$$

$$V_{max} 720 \text{ V} \quad 0.5 \text{ series}$$

Secondary nominal current 5 A

Optional secondary nominal current 1 A

primary nominal current A	nominal power for sec. 5 A	
	class 0.5 VA	class 1 VA
50		1.5
60		2.5
75; 80	2.5	2.5
100	2.5	2.5
150	2.5	2.5
	5	5
200	2.5	2.5
	5	5
250	2.5	
	5	5
	10	10
300	2.5	
	5	5
	10	10
400	2.5	
	5	5
	10	10
500	2.5	
	5	5
	10	10
600	2.5	
	5	5
	10	10
	15	15
750	5	5
	10	10
	15	15

ACCESSORIES

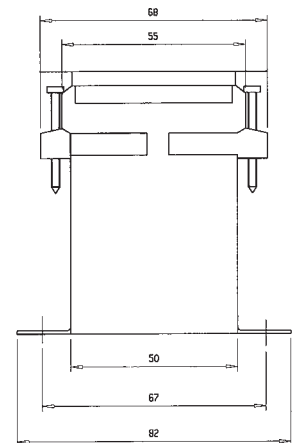
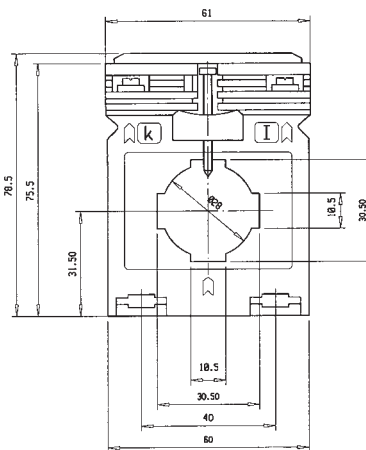

Standard foot mounting
with terminal cover

Snap-on mounting for 35 mm DIN rail available

More transformer types on request

Plug-on Current Transformer Type ASK 41.4

Primary conductor 40 x 10 mm
Circular conductor 32.0 mm Ø



primary nominal current A	nominal power for sec. 5 A	
	class 0.5 VA	class 1 VA
75; 80		1.5
100	1.5	2.5
	2.5	3.75
150	2.5	2.5
		5
200	2.5	2.5
	5	5
250	2.5	2.5
	5	5
		10
300 400	2.5	2.5
	5	5
	10	10
500	2.5	2.5
	5	5
		10
600	2.5	2.5
	5	5
	10	10
		15
750 800	5	5
	10	10
		15
1000	5	5
	10	10

This current transformer corresponds to VDE 0414/1-3 DIN 42600 and IEC 185.

Unbreakable plastic housing with glass-fibre reinforcement, self-extinguishing, low flammable. Transformer housing ultrasonically welded

Nominal frequency 50 Hz (also applicable at 60 Hz); insulation class E; overload factor M 5

$$I_{th} = 60 I_{1N} \text{ (} I_{1N} \text{ for 1 s duration) ;}$$

$$V_{max} 720 \text{ V} \quad 0.5 \text{ series}$$

Secondary nominal current 5 A
Optional secondary nominal current 1 A

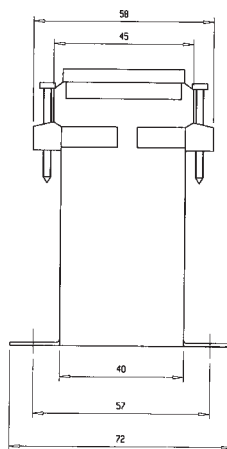
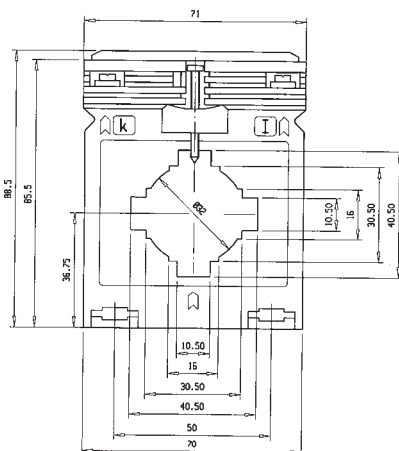

Standard foot mounting with terminal cover

Snap-on mounting for 35 mm DIN rail available

More transformer types on request

ACCESSORIES

Plug-on Current Transformer Type ASK 51.4



Primary conductor 50 x 12 mm

(2 x 40 x 10 mm)
Circular conductor 44.0 mm Ø

This current transformer corresponds to VDE 0414/1-3, DIN 42600 and IEC 185.

Unbreakable plastic housing, Macrolon black, self-extinguishing, low flammable. Transformer housing ultrasonically welded.

Nominal frequency 50 Hz (also applicable at 60 Hz);
Insulation class E;
Overload factor M 5

$I_{th} = 60 I_{1N}$ (I_{1N} for 1 s duration);

V_{max} 720 V 0.5 series

Secondary nominal current 5 A

Optional secondary nominal current 1 A

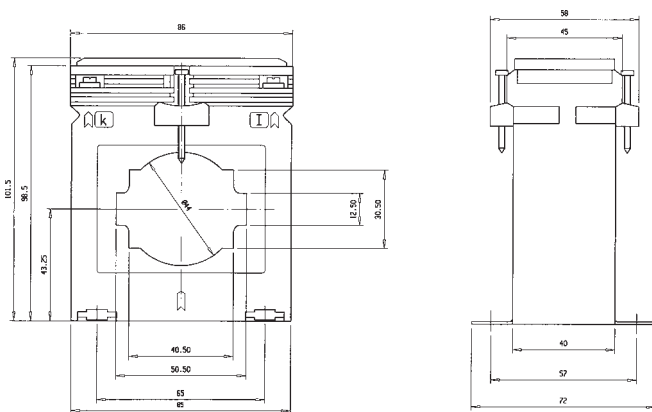

primary nominal current A	nominal power for sec. 5 A	
	class 0.5 VA	class 1 VA
150	1.5	1.5
		2.5
200	1.5	2.5
	2.5	5
250	1.5	2.5
	2.5	5
300	1.5	2.5
	2.5	5
	5	10
400	2.5	2.5
	5	5
	10	10
500	2.5	2.5
	5	5
	10	10
		15
600	2.5	2.5
	5	5
	10	10
		15
750	2.5	2.5
	5	5
	10	10
800		15
	5	5
	10	10
1000	15	15
1200	5	5
	10	10
	15	15

Standard foot mounting
with terminal cover

More transformer types on request

ACCESSORIES

Plug-on Current Transformer Type ASK 61.4

Primary conductor 60 x 10 mm

(2 x 50 x 10 mm)

Circular conductor 44.0 mm Ø



primary nominal current A	nominal power for sec. 5 A	
	class 0.5 VA	class 1 VA
250	1.5	1.5
	2.5	2.5
300	1.5	1.5
	2.5	2.5
	5	5
400	1.5	1.5
	2.5	2.5
	5	5
		10
500	1.5	2.5
	2.5	5
	5	10
		15
600	2.5	2.5
	5	5
	10	10
		15
750	2.5	2.5
	5	5
	10	10
		15
800	2.5	2.5
	5	5
	10	10
	15	15
1000	5	5
	10	10
	15	15
1200	5	5
	10	10
	15	15
		30
1250	5	5
	10	10
	15	15
1500		30
	5	5
	10	10
	15	15

This current transformer corresponds to VDE 0414/1-3 DIN 42600 and IEC 185.

Unbreakable plastic housing, Macrolon black, self-extinguishing, low flammable, transformer housing ultrasonically welded.

Nominal frequency 50 Hz (also applicable at 60 Hz); insulation class E; overload factor M 5.

$$I_{th} = 60 I_{1N} \text{ (} I_{1N} \text{ for 1 s duration) ;}$$

$$V_{max} 720 \text{ V} \quad 0.5 \text{ series}$$

Secondary nominal current 5 A

Optional secondary nominal current 1 A

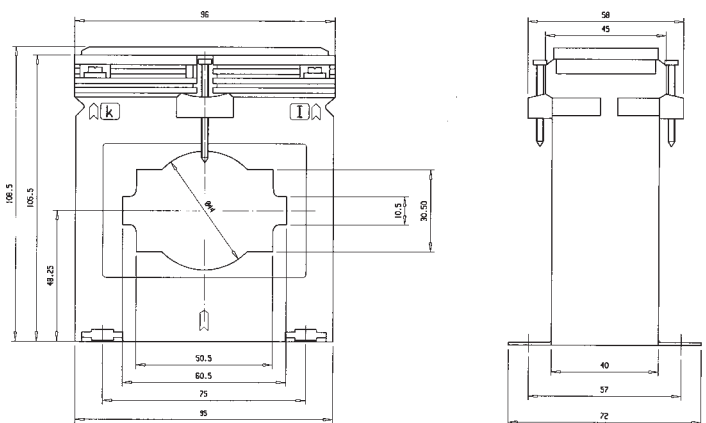

ACCESSORIES

Standard foot mounting with terminal cover

More transformer types on request

Plug-on Current Transformer Type ASK 63.6



Primary conductor 60 x 30 mm

Circular conductor 30.0 mm Ø

This current transformer corresponds to VDE 0414/1-3, DIN 42600 and IEC 185.

Unbreakable plastic housing, Macrolon black, self-extinguishing, low flammable. Transformer housing ultrasonically welded.

Nominal frequency 50 Hz (also applicable at 60 Hz);
Insulation class E;
Overload factor M 5 (from 2000 A: M 10)

$$I_{th} = 60 I_{1N} \text{ (} I_{1N} \text{ for 1 s duration)};$$

$$V_{max} \text{ 720 V} \quad \text{0.5 series}$$

Secondary nominal current 5 A

Optional secondary nominal current 1 A

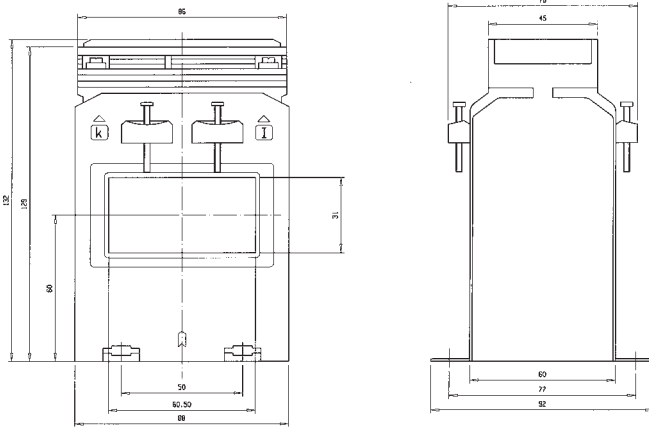

Standard foot mounting
with terminal cover

More transformer types on request

primary nominal current A	nominal power for sec. 5 A	
	class 0.5 VA	class 1 VA
200		2.5
250	2.5	2.5
300	2.5	2.5
	5	5
400	2.5	2.5
	5	5
500	2.5	2.5
	5	5
		10
		15
600	2.5	2.5
	5	5
	10	10
		15
750	2.5	2.5
	5	5
	10	10
		15
800	2.5	2.5
	5	5
	10	10
		15
1000	5	5
	10	10
	15	15
		30
1200	5	5
	10	10
	15	15
		30
1250	5	5
	10	10
	15	15
		30
1500	5	5
	10	10
	15	15
		30
1600	5	5
	10	10
	15	15

ACCESSORIES

Plug-on Current Transformer Type ASK 81.4

Primary conductor 80 x 10 mm
(2 x 60 x 10 mm)
Circular conductor 59.0 mm Ø



primary nominal current A	nominal power for sec. 5 A	
	class 0.5 VA	class 1 VA
500	2.5	2.5
		5
		10
600	2.5	2.5
	5	5
	10	10
750	2.5	2.5
	5	5
	10	10
		15
800	2.5	2.5
	5	5
	10	10
		15
1000	5	5
	10	10
	15	15
1200	5	5
	10	10
	15	15
1250	5	5
	10	10
	15	15
1500	5	10
	10	15
	15	30
1600	5	10
	10	15
	15	30
2000	10	10
	15	15
		30

This current transformer corresponds to VDE 0414/1-3, DIN 42600 and IEC 185.

Unbreakable plastic housing, Macrolon black, self-extinguishing, low flammable, transformer housing ultrasonically welded.

Nominal frequency 50 Hz (also applicable at 60 Hz); Insulation class E; Overload factor M 5 (from 2000 A: M 10)

$$I_{th} = 60 I_{1N} \text{ (} I_{1N} \text{ for 1 s duration) ;}$$

V_{max} 720 V 0.5 series

Secondary nominal current 5 A
Optional secondary nominal current 1 A

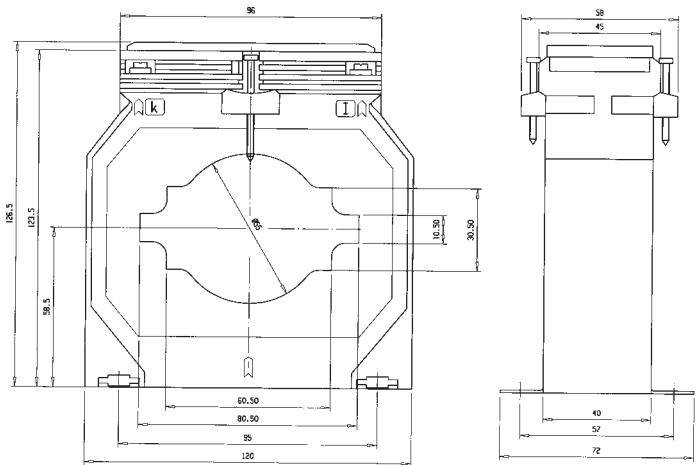

ACCESSORIES

Standard foot mounting with terminal cover

More transformer types on request

Plug-on Current Transformer Type ASK 101.4



Primary conductor 100 x 10 mm

(2 x 80 x 10 mm)

Circular conductor 70,0 mm Ø

This current transformer corresponds to VDE 0414/1-3, DIN 42600 and IEC 185.

Unbreakable plastic housing, Macrolon black, self-extinguishing, low flammable. Transformer housing ultrasonically welded.

Nominal frequency 50 Hz (also applicable at 60 Hz);
Insulation class E;
Overload factor M 5 (from 2000 A: M 10)

$$I_{th} = 60 I_{1N} \text{ (} I_{1N} \text{ for 1 s duration)};$$

$$V_{max} 720 \text{ V} \quad 0.5 \text{ series}$$

Secondary nominal current 5 A

Optional secondary nominal current 1 A

primary nominal current A	nominal power for sec. 5 A	
	class 0.5 VA	class 1 VA
600	2.5	5
	5	10
750	5	5
	10	10
800	5	5
	10	10
1000	5	5
	10	10
		15
1200 1250	5	5
	10	10
		15
1500		30
	5	5
	10	10
	15	15
1600		30
	5	10
	10	15
	15	30
1800		
	5	10
	10	15
	15	30
2000		45
	5	10
	10	15
	15	30

ACCESSORIES

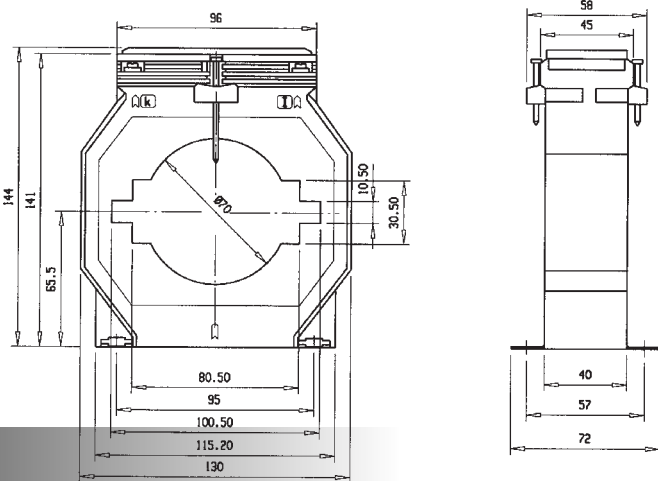

Standard foot mounting
with terminal cover

More transformer types on request

Plug-on Current Transformer Type ASK 103.3

Primary conductor 2 x 100 x 10 mm

3 x 80 x 10 mm

Circular conductor 85,0 mm Ø



primary nominal current A	nominal power for sec. 5 A	
	class 0.5 VA	class 1 VA
750	2.5	5
	5	10
800	2.5	5
	5	10
	10	15
1000	5	5
	10	10
	15	15
1200	5	5
	10	10
	15	15
1250		30
	5	5
	10	10
	15	15
1500		30
	10	10
	15	15
		30
1600	10	10
	15	15
		30
2000	10	10
	15	15
	30	30
2500	10	10
	15	15
	30	30
3000	10	10
	15	15
	30	30

This current transformer corresponds to VDE 0414/1-3 DIN 42600 and IEC 185.

Unbreakable plastic housing, Macrolon black, self-extinguishing, low flammable, transformer housing ultrasonically welded.

Nominal frequency 50 Hz (also applicable at 60 Hz); Insulation class E; Overload factor M 5 (from 2000 A: M 10)

$$I_{th} = 60 I_{1N} \text{ (} I_{1N} \text{ for 1 s duration) ;}$$

$$V_{max} 720 \text{ V} \quad 0.5 \text{ series}$$

Secondary nominal current 5 A
Optional secondary nominal current 1 A

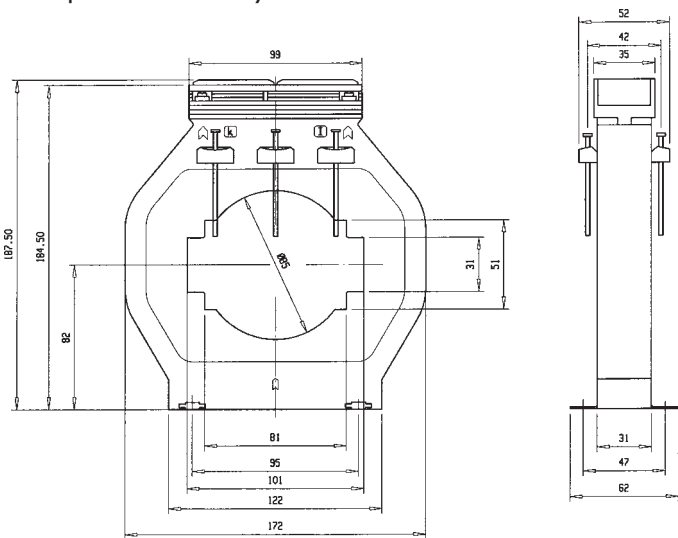

ACCESSORIES

Standard foot mounting with terminal cover

More transformer types on request

Plug-on Current Transformer Type ASK 105.6



Primary conductor 100 x 55 mm

This current transformer corresponds to VDE 0414/1-3, DIN 42600 and IEC 185.

Unbreakable plastic housing, Macrolon black, self-extinguishing, low flammable. Transformer housing ultrasonically welded.

Nominal frequency 50 Hz (also applicable at 60 Hz);
Insulation class E;
Overload factor M 5 (from 2000 A: M 10)

$$I_{th} = 60 I_{1N} \text{ (} I_{1N} \text{ for 1 s duration)};$$

$$V_{max} 720 \text{ V} \quad 0.5 \text{ series}$$

Secondary nominal current 5 A
Optional secondary nominal current 1 A

primary nominal current A	nominal power for sec. 5 A	
	class 0.5 VA	class 1 VA
600	2.5	5
	5	10
700	5	5
	10	10
800	5	5
	10	10
1000	5	5
	10	10
1200	5	5
	10	10
	15	15
1250	5	5
	10	10
	15	15
1500	5	5
	10	10
	15	15
	30	30
1800	5	5
	10	10
	15	15
		30
2000	5	10
	15	30
	30	45
2500	5	10
	10	15
	30	45
3000	5	10
	10	15
	15	30
	30	45

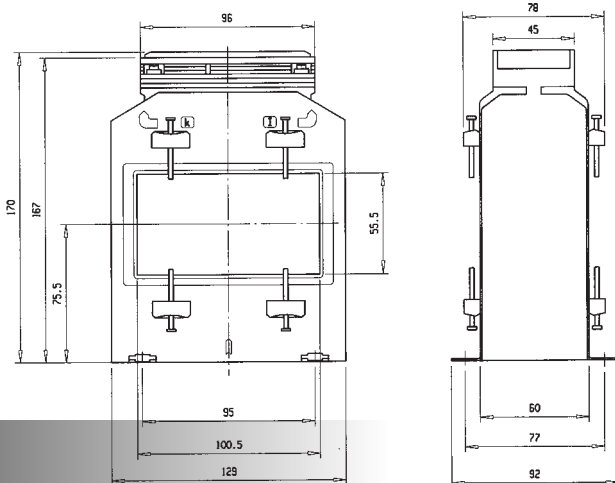

ACCESSORIES

Standard foot mounting
with terminal cover

More transformer types on request

Plug-on Current Transformer Type ASK 127.6

Primary conductor 120 x 72 mm
(2 x 80 x 10 mm)



primary nominal current A	nominal power for sec. 5 A	
	class 0.5 VA	class 1 VA
1000	5	5
		10
1200	5	10
	10	15
1250	10	10
	15	15
	30	30
1500	10	10
	15	15
	30	30
1800	10	10
	15	15
	30	30
2000	10	10
	15	15
	30	30
2500	10	10
	15	15
	30	30
3000	10	10
	15	15
	30	30
4000	10	10
	15	15
	30	30
5000	10	10
	15	15
	30	30
6000		45
	10	10
	15	15
	30	30
		45

This current transformer corresponds to VDE 0414/1-3 DIN 42600 and IEC 185.

Unbreakable plastic housing, Macrolon black, self-extinguishing, low flammable, transformer housing ultrasonically welded.

Nominal frequency 50 Hz (also applicable at 60 Hz); Insulation class E; Overload factor M 5 (from 2000 A: M 10)

$$I_{th} = 60 I_{1N} \text{ (} I_{1N} \text{ for 1 s duration) ;}$$

$$V_{max} 720 \text{ V} \quad 0.5 \text{ series}$$

Secondary nominal current 5 A
Optional secondary nominal current 1 A

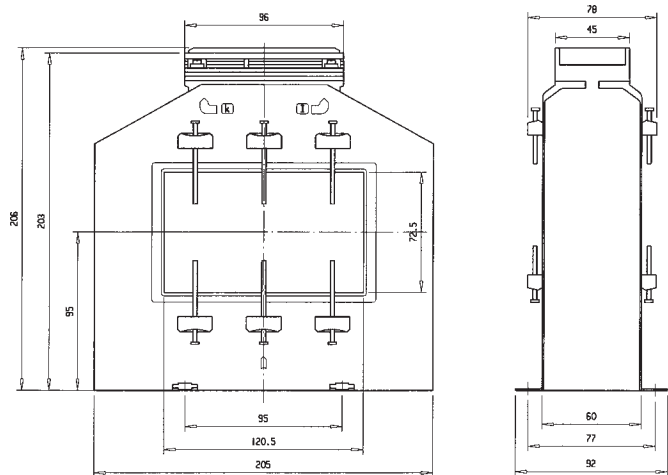

ACCESSORIES

Standard foot mounting with terminal cover

More transformer types on request

Plug-on Current Transformer Type ASK 130.5

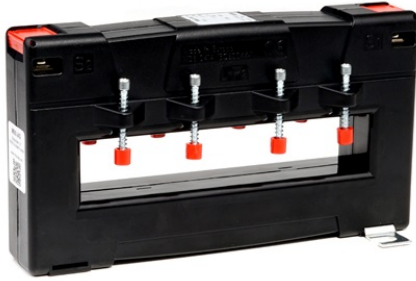

**Primary conductor
30 x 30 mm**

This current transformer corresponds to VDE 0414/1-3, DIN 42600 and IEC 185.

Unbreakable plastic housing, Macrolon black, self-extinguishing, low flammable. Transformer housing ultrasonically welded.

Nominal frequency 50 Hz (also applicable at 60 Hz);
Insulation class E;
Overload factor M 5 (from 2000 A: M 10)

$$I_{th} = 60 I_{1N} \text{ (} I_{1N} \text{ for 1 s duration)};$$

$$V_{max} 720 \text{ V} \quad 0.5 \text{ series}$$

Secondary nominal current 5 A

Optional secondary nominal current 1 A

primary nominal current A	nominal power for sec. 5 A	
	class 0.5 VA	class 1 VA
300	5 10	5 10
400	5 10	5 10
500	5 10 15	5 10 15
600	5 10 15	5 10 15
750	10 15	10 15
1000	10 15 30	10 15 30
1200	10 15 30	10 15 30
1250	10 15 30	10 15 30
1500	10 15 30	10 15 30 45
1600	10 15 30	10 15 30
2000	10 15 30	10 15 30
2400	10 15 30	10 15 30
2500	10 15 30	10 15 30
3000	10 15 30	10 15 30
3200	10 15 30	10 15 30

ACCESSORIES

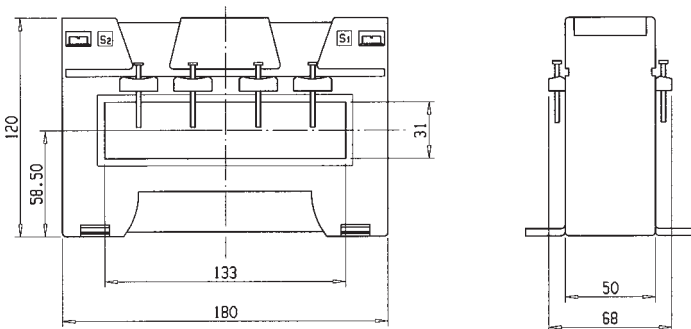

Standard foot mounting
with terminal cover

More transformer types on request

Wound-Primary Current Transformer Type WSK 30

primary nominal current A	nominal power for sec. 5 A	
	class 0.5 VA	class 1 VA
1	2.5	2.5
2,5	2.5	5
5	2.5	5
10	2.5	5
15	2.5	5
20	2.5	25
		5



Secondary nominal current 5 A
Optional secondary nominal current 1 A

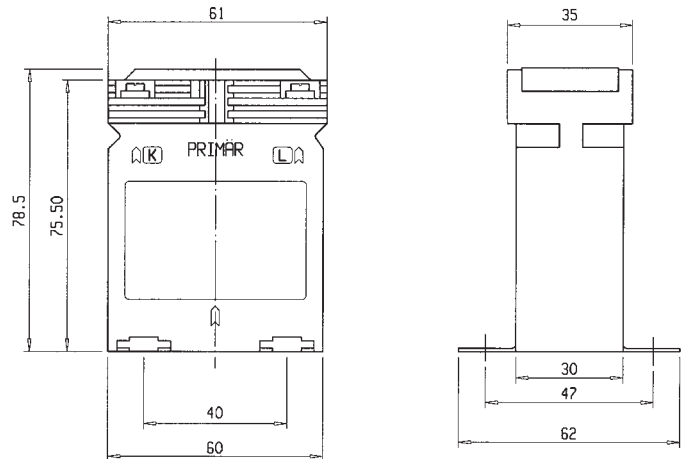

Standard foot mounting
with terminal cover

Snap-on mounting for
35 mm DIN rail available

More transformer types on request

ACCESSORIES

Wound-Primary Current Transformer Type WSK 40



Secondary nominal current 5 A
Optional secondary nominal current 1 A

primary nominal current A	nominal power for sec. 5 A	
	class 0.5 VA	class 1 VA
1	2.5	2.5
	5	5
	10	10
2,5	2.5	2.5
	5	5
	10	10
5	2.5	2.5
	5	5
	10	10
10	2.5	2.5
	5	5
	10	10
15	2.5	2.5
	5	5
	10	10
20	2.5	2.5
	5	5
	10	10
25	2.5	2.5
	5	5
	10	10
30	2.5	2.5
	5	5
	10	10

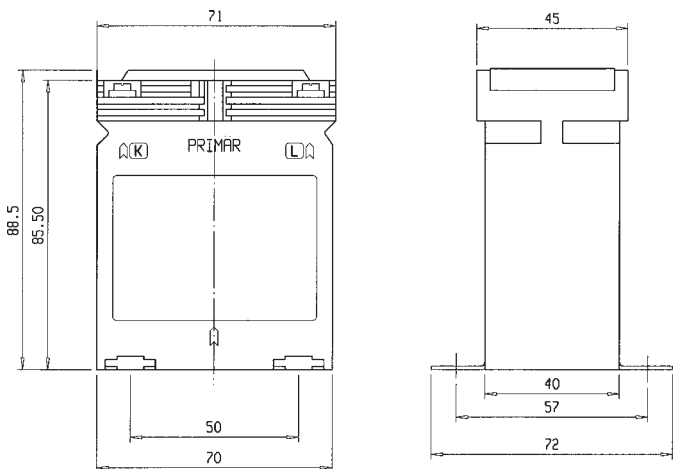

Standard foot mounting
with terminal cover

Snap-on mounting for
35 mm DIN rail available

More transformer types on request

Wound-Primary Current Transformer Type WSK 60



primary nominal current A	nominal power for sec. 5 A	
	class 0.5 VA	class 1 VA
5	2.5	2.5
	5	5
	10	10
		15
10	2.5	2.5
	5	5
	10	10
		15
15	2.5	2.5
	5	5
	10	10
		15
20	2.5	2.5
	5	5
	10	10
		15
25	2.5	2.5
	5	5
	10	10
		15
30	2.5	2.5
	5	5
	10	10
		15

Secondary nominal current 5 A
Optional secondary nominal current 1 A

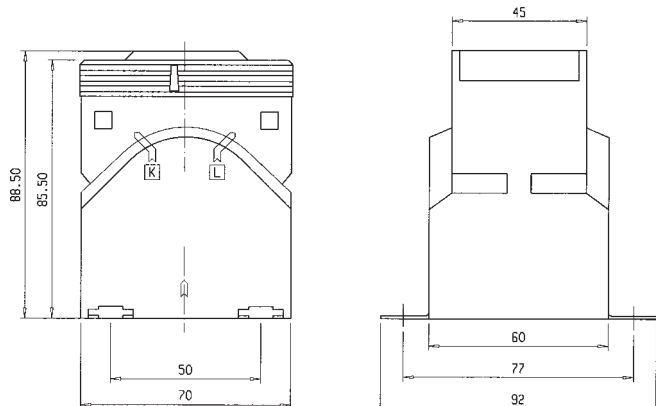

Standard foot mounting
with terminal cover

ACCESSORIES

More transformer types on request



Split Core Current Transformer Type KBU

Subsequent installation e.g. onto a bus bar is possible by means of a user-friendly clip fastener.

This current transducer corresponds to VDE 0414/1
DIN 42600 and EN 60044/1.

Nominal frequency 50 Hz
(also applicable at 60 Hz);
Insulation class E
Overload factor M5 (from 2000A: M 10)

$$I_{th} = 60 I_{1N} \text{ (} I_{1N} \text{ for 1 s duration)};$$

V_{max} 720 V 0.5 series

Secondary nominal current 5 A

Optional secondary nominal current 1 A

Safety instruction:

The contact surfaces of the split cores
Have to be free of grime!
The transformer must only be
operated in shut state!

Standard foot mounting
terminal cover

primary (A)	KBU 23		KBU 58		KBU 812		KBU 816	
	1	3	0.5	1	0.5	1	0.5	1
100		1.25						
150		1.5						
200		2.5						
250	1.5			1.5		1.5		
300	3.75			2.5		2.5		
400	5		1	2.5		2.5		
500			2.5	5	2.5	5		
600			2.5	5	2.5	5		
750			2.5	5	2.5	5		
800			2.5	7.5	2.5	7.5		
1000			5	10	5	10	10	10
1200					5	10	10	15
1250					7.5	15		
1500					7.5	15	15	15
1600							15	15
2000							15	15
2500							15	15
3000							15	30
4000							15	30
5000							15	30

All entries in VA

Dimensions (in mm)

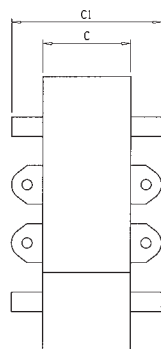
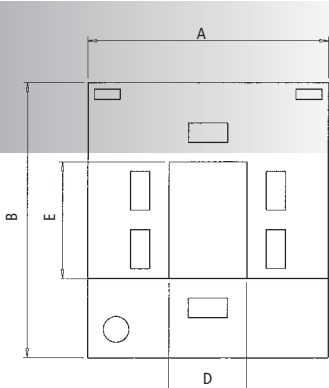

Type	A	B	C/C1	D	E	weight
KBU 23	93	106	34/58	20	30	850 g
KBU 58	125	152	34/58	50	80	1080 g
KBU 812	155	198	34/58	80	120	1320 g
KBU 816	195	243	64/79	80	160	3780 g

THE "CLASSICS"

- **Reliable**
- **Robust**
- **Space-saving**

Available in the following versions:

MA-1.1s

MV-1.1s

MF-1.1

MPlz.1

MW-1.1,

MWg-3.1, MWg-4.1

MWu-3.1, MWu-4.1

MA-G.1

MV-G.1

MT-G.1

MPt.1, MTh.1

MWi.1

RM.1

- transducer for AC current
- transducer for AC voltage
- frequency transducer
- transducer for power factor
- transducer for active power for alternating current and three-phase alternating current (also available for reactive power)
- transducer for DC current
- transducer for DC voltage
- buffer amplifier
- temperature transducer
- remote resistance sensing transducer
- relay module for transducer

General data:

Conformity:

These transducers correspond to the regulations of the guideline of the Council of the European Union concerning the approximation of laws of the member states referring to the electromagnetic compatibility, EMC-guideline 89/336/EWG, as well as the low voltage guideline 73/23/EWG.

Operation manual:

The operation manual is part of the delivery and has to be followed during every assembly work.

DIN regulations:

EMC
Mechanical firmness
Electric safety

DIN EN 50081-1, DIN EN 61000-6-2
DIN EN 61010 Part 1
DIN EN 61010 Part 1
Housing safety insulated, protective class II
working voltage up to 300 V (fuse to neutral conductor)
contamination level 2, overvoltage cat. CAT III
working voltage up to 600 V (fuse to neutral conductor)
contamination level 2, overvoltage cat. CAT II

Accuracy
Overload
Separation
Air and creepage distance
Protective class
Connection

DIN EN 60688
DIN EN 60688
DIN EN 61010 Part 1, 3.7 kV 50 Hz 1 min.
DIN EN 61010 Part 1
DIN EN 60529, housing IP 30, terminals IP 20
DIN EN 43807

TRANSDUCCERS

AC Transducer (sinusoidal) Type MA-1.1s

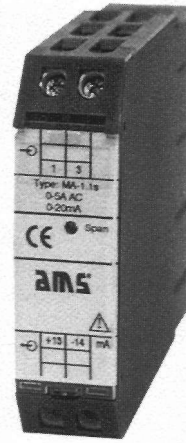

The transducers MA-1.1s are used to convert sinusoidal alternating current into an impressed signal of direct current and / or direct voltage. The alternating current to be measured reaches the subsequent rectifier circuit via an internal circuit converter, which is used for the galvanic separation. The direct voltage obtained is increased and converted into an impressed direct current or direct voltage. The output is idle protected and short-circuit protected.

Input

Input current	sinusoidal alternating current
Rated frequency	0 – 1 A or 0 – 5 A
Internal consumption	50 Hz, 60 Hz or 400 Hz
Permanent overload	approx. 1 VA, at „live zero“ (auxiliary voltage) 0.3 VA
Shock overload	2-fold
	20-fold, max. 1 s

Output

Rated values	single output or double output
Single output	0 – 20 mA, load resistance 0 – 500 Ω
	0 – 10 V, max. 20 mA loadable
	4 – 20 mA, load resistance 0 – 500 Ω
Double output	0 – 20 mA and 0 – 10 V
	reversible to
	4 – 20 mA and 2 – 10 V
	load resistance for 20 mA and 4 – 20 mA: 0 – 500 Ω
	10 V and 2 – 10 V: max. 10 mA loadable

without auxiliary voltage
without auxiliary voltage
with auxiliary voltage
with auxiliary voltage

Auxiliary voltage

Standard	230 V AC, ± 20 %, 45 – 65 Hz, 2.5 VA
Special versions	110 V AC, ± 20 %, 45 – 65 Hz, 2.5 VA
	or 24 V DC, – 15 % to + 25 %, 2 VA
	or 36 – 265 V AC + DC, 2 VA

Accuracy

± 0.5 % at 5 – 100 % I_n
with auxiliary voltage 0 – 100 % I_n

Adjustment

the measurement output end value can be readjusted
single output 0 – 20 mA or 0 – 10 V; potentiometer „SPAN“
4 – 20 mA; potentiometer „ZERO“
(see operation manual)

Switchover

On double outputs type MA-1.1s, switching position "live zero"
(4 - 20 mA / 2 - 10 V) or switching position "zero"
(0 – 20 mA / 2 – 10 V) can be adjusted by using
the front-side sliding switch.

Mechanical data

Housing	DIN rail housing for 35 mm DIN rail, DIN EN 50022 width 22.5 mm
Housing material	PC (UL 94-V1), terminals PA (UL 94-V0)
Weight	approx. 190 g
Connection	screw connection, max. 4 mm

Type MA-1.1s (Alternating current)

Transmission behaviour

Frequency influence	< 0.01 % at 10 Hz frequency variation
Temperature range	- 15°C to + 55°C
Temperature influence	< 0.1 % at 10 K
Influence of auxiliary voltage	no
Influence of load resistance	no
Influence of external field	no (400 A/m)
Voltage ripple	< 40 mV _{ss}
Setting time	< 400 ms
Idle voltage	max. 24 V
Current limitation	max. 2-fold at override
Test voltage	4 kV between input-output-auxiliary voltage

Circuit diagrams

measurement of alternating current (sinusoidal)

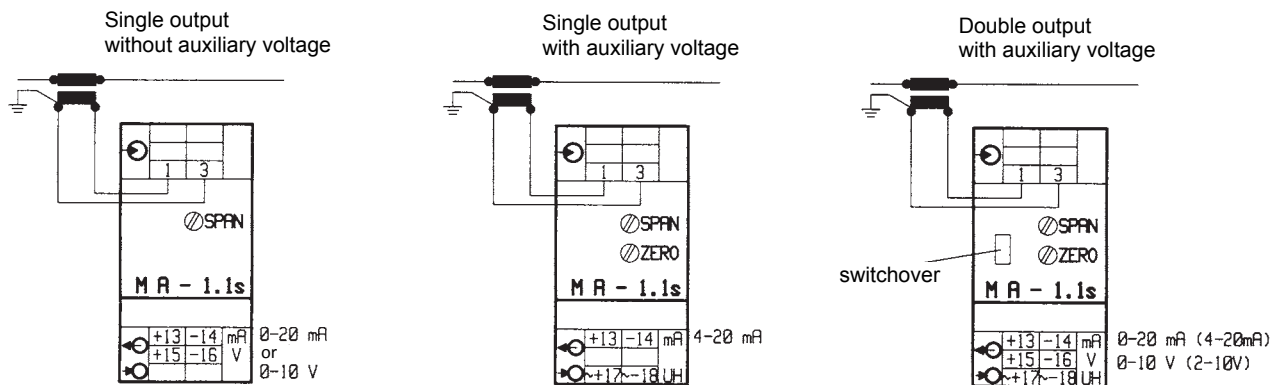

For double output, a connection of the two outputs is not permitted!

Scale drawing

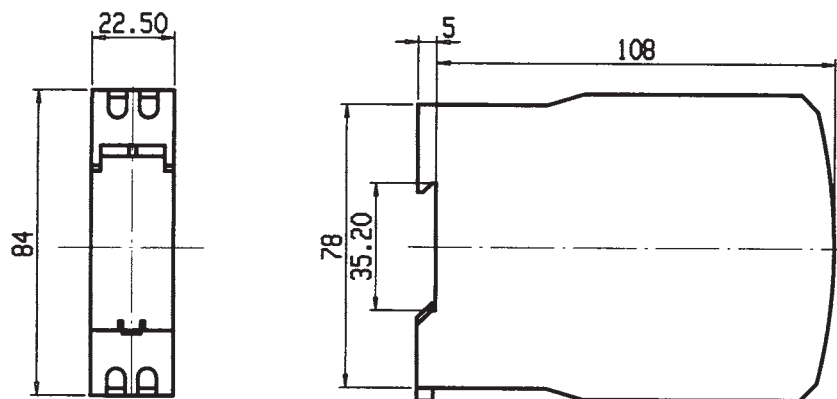

TRANSDUCERS

Optional:

The relay module type RM.1 is available for the limit value monitoring.

Transducer for alternating voltage (sinusoidal) Type MV-1.1s

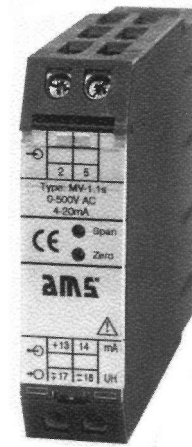

The transducers MA-1.1s are used to convert and separate sinusoidal alternating voltage into an impressed signal of direct current and / or direct voltage. The alternating voltage to be measured reaches the subsequent rectifier circuit via an internal voltage converter, which is used for the galvanic separation. The direct voltage obtained here, is increased and converted into an impressed direct current or direct voltage. The output is idle and short-circuit protected.

Input	sinusoidal alternating voltage	
Input voltages	0 – 100 V, 0 – 250 V or 0 – 500 V 0 – 600 V or 0 – 750 V (only in combination with auxiliary voltage) range 0 to 750 V only for grounded units	
Nominal frequency	50 Hz, 60 Hz or 400 Hz	
Internal consumption	approx. 1 VA at "live zero" (auxiliary voltage) 0.3 VA	
Permanent overload	1.2-fold	
Shock overload	2-fold, max. 1 sec.	
Output	single or double output	
Nominal values		
Single output	0 – 20 mA, load resistance 0 – 500 Ω 0 – 10 V, max. 20 mA loadable	without auxiliary voltage
	4 – 20 mA, load resistance 0 – 500 Ω	with auxiliary voltage
Double output	0 – 20 mA and 0 – 10 V	with auxiliary voltage
	reversible to 4 – 20 mA and 2 – 10 V load resistance at 20 mA and 4 – 20 mA: 0 – 500 Ω 10 V and 2 – 10 V: max. 10 mA loadable	
Auxiliary voltage		
Standard	230 V AC, ± 20 %, 45 – 65 Hz, 2.5 VA	
Special versions	110 V AC, ± 20 %, 45 – 65 Hz, 2.5 VA	
	or 24 V DC, – 15 % to + 25 %, 2 W	
	or 36 – 265 V AC + DC, 2 VA	
Accuracy	± 0,5 % at 5 – 100 % Un with auxiliary voltage 0 – 100 % Un	
Adjustment	the end value of the measurement output can be readjusted single output 0 – 20 mA or 0 – 10 V trimpot "SPAN" 4 – 20 mA trimpot "ZERO" (see operation manual)	
Switchover	on double outputs type MV-1.1s, switching position "live zero" (4 – 20 mA/2 – 10 V) or switching position "zero" (0 – 20 mA/0 – 10 V) can be adjusted by using the front-side sliding switch (see operation manual).	
Mechanical data		
Housing	housing for 35 mm DIN rail, DIN EN 50022 width 22.5 mm	
Housing material	PC (UL 94-V1), terminals PA (UL 94-V0)	
Weight	approx. 190 g	
Connection	screw connection max. 4 mm ²	

Type MV-1.1s (Alternating voltage)

Transmission behaviour

Frequency influence	< 0.01 % at 10 Hz frequency variation
Temperature range	- 15°C to + 55°C
Temperature influence	< 0.1 % at 10 K
Influence of auxiliary voltage	no
Influence of load resistance	no
Influence of external field	no (400 A/m)
Voltage ripple	< 40 mV _{ss}
Setting time	< 400 ms
Idle voltage	max. 24 V
Current limitation	max. 2-fold at override
Test voltage	4 kV between input-output-auxiliary voltage

Circuit diagrams

measurement of alternating voltage (sinusoidal)

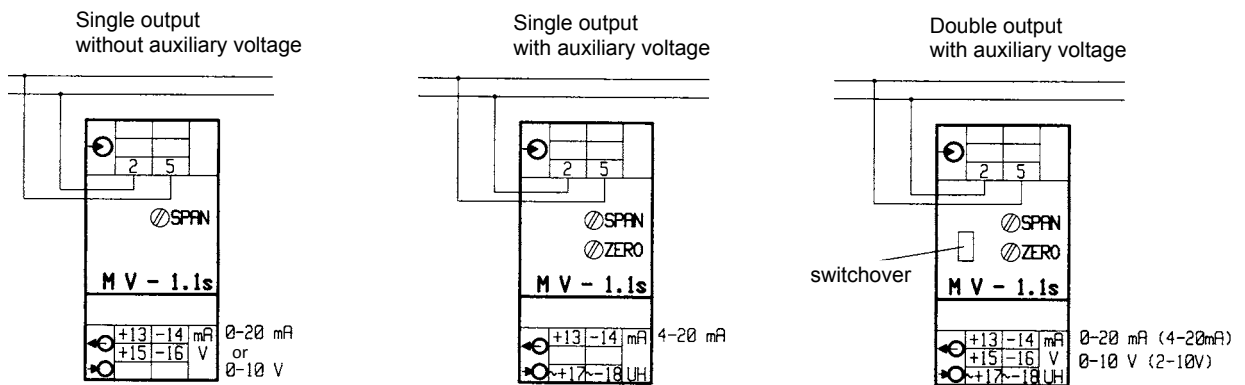

For double output, a connection of the two outputs is not permitted!

Scale drawing

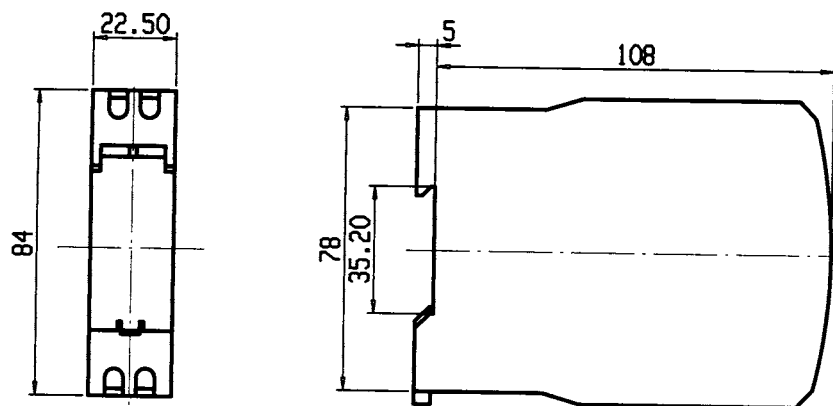

TRANSDUCERS

Optional:

The relay module type RM.1 is available for the limit value monitoring.

Frequency transducers Type MF-1.1



The transducers MF-1.1 are used to convert and separate a frequency into an impressed signal of direct current and direct voltage. The frequency to be measured reaches a filter and subsequently a microcontroller applying the evaluation via an internal voltage converter, which is used for the galvanic separation. The direct voltage obtained here, is converted into an impressed direct current and an impressed direct voltage.

- DOUBLE OUTPUT - Both outputs are idle and short-circuit protected.

Input	frequency	
Standard frequencies	45 – 55 Hz, 55 – 65 Hz or 360 – 440 Hz	
Special frequencies	48 – 52 Hz, 58 – 62 Hz or 380 – 420 Hz	
Nominal voltages	0 – 100 Hz, 0 – 500 Hz or 0 – 1000 Hz (only with auxiliary voltage)	
Special nominal voltages	100 V, 110 V, 230 V or 400 V	
Internal consumption	2 – 50 V, 25 – 250 V or 75 – 690 V (only with auxiliary voltage)	
	2.5 – 4 VA	
	1 – 1.5 VA with auxiliary voltage	
Permanent overload	1.2-fold	
Shock overload	2-fold, max. 1 sec.	
Output	double output	
Nominal values	0 – 20 mA and 0 – 10 V	without auxiliary voltage
	or	
	2 – 40 mA and 2 – 10 V	with auxiliary voltage
	load resistance at 20 mA and 4 – 20 mA: 0 – 500 Ω	
	10 V and 2 – 10 V: max. 10 mA loadable	
Auxiliary voltage		
Standard	230 V AC, ± 20 %, 45 – 65 Hz, 2.5 VA	
Special versions	110 V AC, ± 20 %, 45 – 65 Hz, 2.5 VA	
	or	
	24 V DC, – 15 % to + 25 %, 2 W	
	or	
	36 – 265 V AC + DC, 2 VA	
Accuracy	± 0.5 %	
Mechanical data		
Housing	housing for 35 mm DIN rail, DIN EN 50022	
	width 22.5 mm	
Housing material	PC (UL 94-V1), terminal PA (UL 94-V0)	
Weight	approx. 190 g	
Connection	screw connection max. 4 mm ²	

Type MV-1.1s (Alternating voltage)

Transmission behaviour

Temperature range	- 15°C to + 55°C
Temperature influence	< 0.1 % at 10 K
Influence of auxiliary voltage	no
Influence of load resistance	no
Influence of external field	no (400 A/m)
Voltage ripple	< 30 mV _{ss}
Setting time	< 300 ms
Idle voltage	max. 24 V
Current limitation	max. 2-fold at override
Test voltage	4 kV between input-output-auxiliary voltage

Circuit diagrams

measurement of frequency

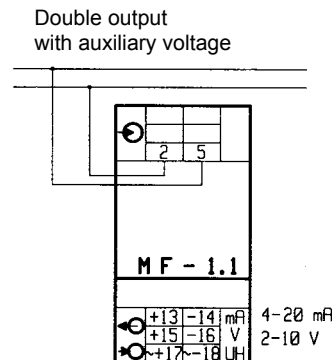
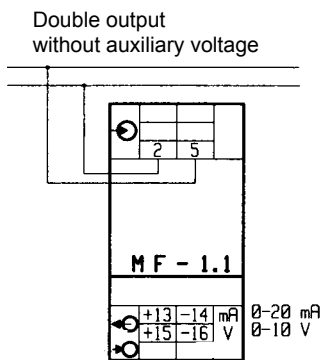

For double output, a connection of the two outputs is not permitted!

Scale drawing

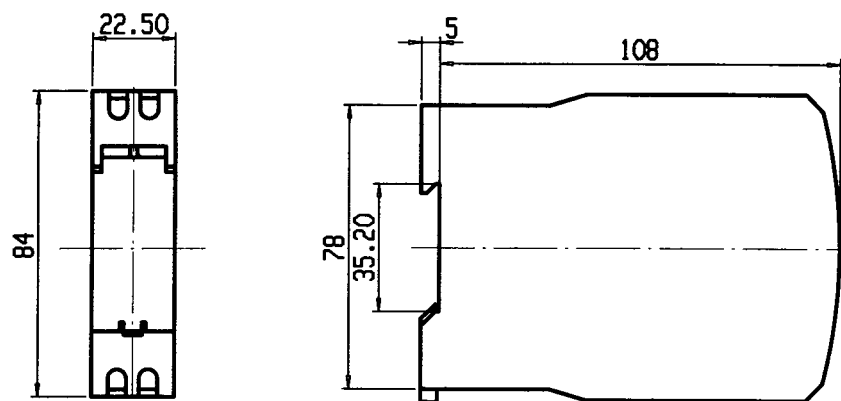

TRANSDUCERS

Optional:
The relay module type RM.1 is available for the limit value monitoring.

Power factor transducer (phase angle)



Type MPLz.1 single-phase alternating current and equally loaded three-phase alternating current

The transducer MPLz.1 is used to convert and separate the phase angle between current and voltage of an AC and/or three-phase network with equal load. The parameters to be measured reach a zero passage comparator via internal current and voltage converters, which are used for the galvanic separation. In the zero passage comparators position, a rectangular signal, which is directly related with the phase angle, is provided. A subsequent level of integration forms the average value of the direct voltage. This direct voltage is converted to an impressed direct current and an impressed direct voltage.

- DOUBLE OUTPUT - Both outputs are idle and short-circuit protected.

Input	<p>phase angle between sinusoidal voltages and currents in AC and/or three-phase networks</p> <p>Standard value Special value Nominal voltages Special voltages Nominal current Internal consumption</p> <p>Nominal frequency Permanent overload Shock overload</p>	<p>cos (phi): cap. 0.5 – 1 – 0.5 ind. (phase angles – 60°... 0 ... + 60°) cos (phi): cap. 0.7 – 1 – 0.3 ind. (phase angles – 45.6°... 0 ... + 72.5°)</p> <p>100 V, 110 V, 230 V, 400 V, 500 V, ± 20 % 690 V ± 20 %, only for grounded units 1 A or 5 A</p> <p>voltage path approx. 2.5 VA current path approx. 0.3 VA</p> <p>50 Hz, 60 Hz or 400 Hz current 2-fold In, voltage 1.2-fold Un current 20-fold In, voltage 2-fold Un, max. 1 sec.</p>
Output	<p>double output</p> <p>0 – 20 mA and 0 – 10 V with auxiliary voltage r e v e r s i b l e t o 4 – 20 mA and 2 – 10 V load at 20 mA and 4 – 20 mA: 0 – 500 Ω 10 V and 2 – 10 V: max. 10 mA loadable</p>	
Auxiliary voltage	<p>Standard Special versions</p> <p>or or</p>	<p>230 V AC, ± 20 %, 45 – 65 Hz, 2.5 VA 110 V AC, ± 20 %, 45 – 65 Hz, 2.5 VA 24 V DC, – 15 % to + 25 %, 2 W 36 – 265 V AC + DC, 2 VA</p>
Accuracy	± 0.5 %	
Mechanical data	<p>Housing</p> <p>Housing material Weight Connection</p>	<p>housing for 35 mm DIN rail, DIN EN 50022 width 22.5 mm PC (UL 94-V1), terminals PA (UL 94-V0) approx. 200 g screw connection max. 4 mm²</p>

Type MP1z. 1 (1-phase and three-phase alternating current)

Transmission behaviour

Current range	4 – 200 % I _n
Current influence	< 0.5 % at 0.15 to 2-fold I _n
Voltage influence	< 0.5 % at ± 20 % U _n
Frequency influence	< 0.1 % at 10 Hz frequency variation
Temperature range	- 15°C to + 55°C
Temperature influence	< 0.2 % at 10 K
Influence of auxiliary voltage	no
Influence of load resistance	no
Influence of external field	no (400 A/m)
Voltage ripple	< 30 mV _{ss}
Setting time	< 400 ms
Idle voltage	max. 24 V
Current limitation	max. 2-fold at override
Test voltage	4 kV between input-output-auxiliary voltage

Circuit diagrams

power factor measurement

single-phase alternating current and
equally loaded three wire three-phase AC

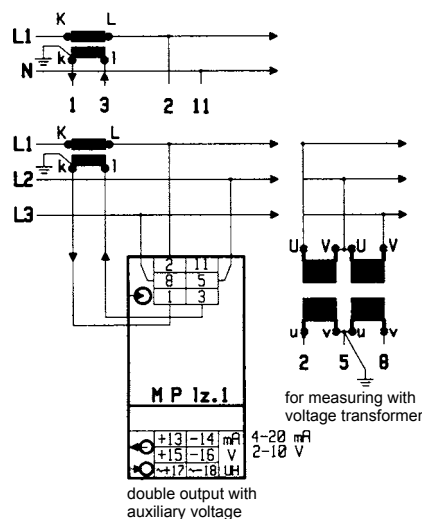

A connection of the two outputs is not permitted!

Scale drawing

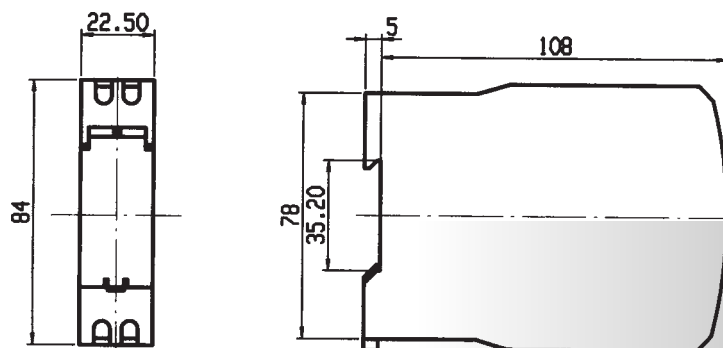

Optional:
The relay module type RM.1 is available for limit value monitoring.

TRANSDUCERS

Transducers for active power

(also available for reactive power)

Type MW-1.1 single-phase AC

Type MWg-3.1 equally loaded three wire three-phase AC

Type MWg-4.1 equally loaded four wire three-phase AC

The transducer types MW-1.1, MWg-3.1 and MWg-4.1 are used to convert and separate the active power in alternating current networks and / or three-phase AC networks into an impressed signal of direct current and direct voltage. The parameters to be measured reach an analogue multiplier via internal current transducers and voltage dividers. Inside the analogue multiplier, the instantaneous values of current and voltage are multiplied and converted into an average value of a direct voltage corresponding to the active power, inside a subsequent integrator. Sinusoidal as well as non-sinusoidal parameters of single-phase alternating current can be measured. The galvanic separation between the input signal and the output signal is ensured by means of an optocoupler. The downstream amplifiers supply the impressed signals of direct current and direct voltage.

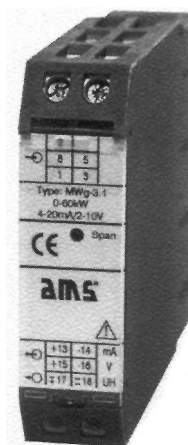

- DOUBLE OUTPUT - Both outputs are idle and short-circuit protected.

Input	active power at single-phase AC or three-phase AC
Nominal values	MW-1.1 single-phase AC ($P_s = U \times I$) 50 – 100 % of the apparent power MWg-3.1 equally loaded three wire three-phase AC ($P_s = U \times I \times 1.73$) 50 – 100 % of the apparent power MWg-4.1 equally loaded four wire three-phase AC ($P_s = U \times I \times 1.73$) 50 – 100 % of the apparent power
Nominal voltages	100 V, 110 V, 230 V, 400 V, 500 V, ± 20 %
Special voltage	690 V ± 20 %, only for grounded units (auxiliary voltage required)
Nominal current	1 A or 5 A
Internal consumption	voltage path approx. 2.5 VA current path approx. 0.3 VA
Nominal frequency	50 Hz, 60 Hz or 400 Hz
Permanent overload	current 2-fold I_n , voltage 1.2-fold U_n
Shock overload	current 20-fold I_n , voltage 2-fold U_n , max. 1 sec.
Output	double output for types MW-1.1, MWg-3.1 or MWg-4.1
Standard output	0 – 20 mA and 0 – 10 V without auxiliary voltage or 4 – 20 mA und 2 – 10 V with auxiliary voltage
Special output	for import and export 20 – 0 – 20 mA and 10 – 0 – 10 V without auxiliary voltage
Load resistance	20 mA and 4 – 20 mA: 0 – 500 Ω 10 V and 2 – 10 V: max. 10 mA loadable
Auxiliary voltage	
Standard	230 V AC, ± 20 %, 45 – 65 Hz, 2.5 VA
Special versions	110 V AC, ± 20 %, 45 – 65 Hz, 2.5 VA
or	24 V DC, – 15 % to + 25 %, 2 W
or	36 – 265 V AC + DC, 2 VA
Accuracy	± 0.5 %
Mechanical data	
Housing	housing for 35 mm DIN rail, DIN EN 50022 width 22.5 mm
Housing material	PC (UL 94-V1), terminals PA (UL 94-V0)
Weight	approx. 200 g
Connection	screw connection max. 4 mm ²

Type MW-1.1 (single-phase alternating current)

Type MWg-3.1 (equally loaded three wire three-phase alternating current)

Type MWg-4.1 (equally loaded four wire three phase current)

Transmission behaviour

Voltage influence	< 0.1 % at ± 10 % of nominal voltage
Frequency influence	< 0.3 % at 10 Hz frequency variation
Influence of phase angle	< 0.5 % at ± 90 degrees
Temperature range	- 15°C to + 55°C
Temperature influence	< 0.3 % to 10 K
Influence of auxiliary voltage	no
Influence of load resistance	no
Influence of external field	no (400 A/m)
Voltage ripple	< 30 mV _{ss}
Setting time	< 300 ms
Idle voltage	max. 24 V
Current limitation	max. 2-fold at override
Test voltage	4 kV between input-output-auxiliary voltage

Circuit diagrams

active power measurement

single-phase alternating current

equally loaded three wire three-phase alternating current

equally loaded four wire three-phase alternating current

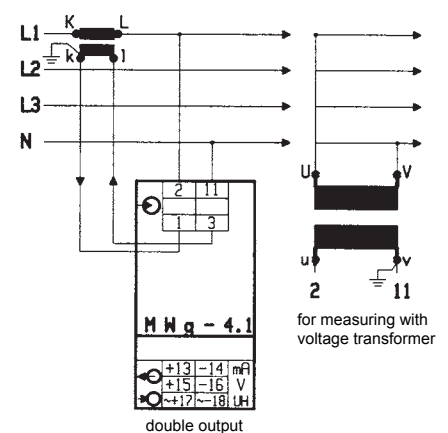
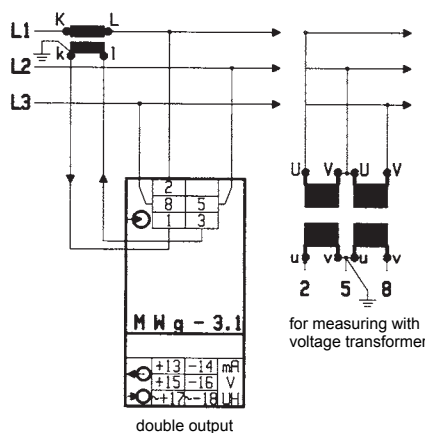
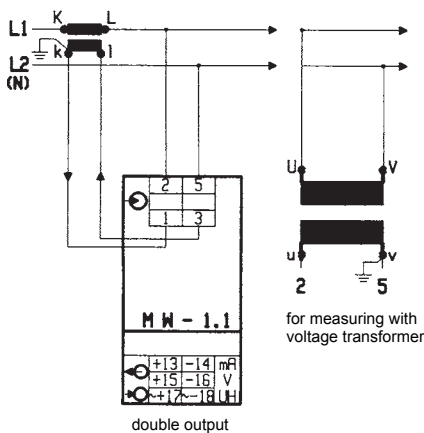

For double output, a connection of the two outputs is not permitted!

Scale drawing

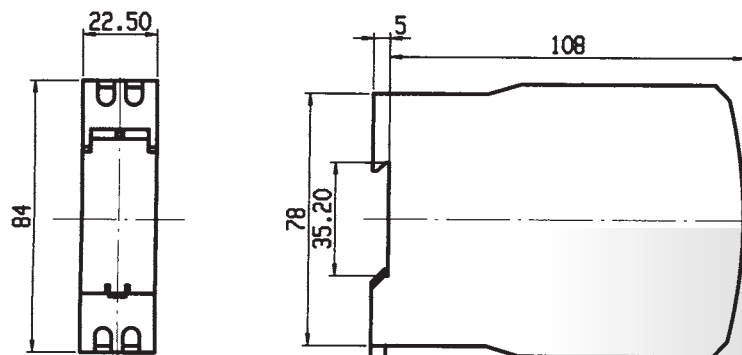

Optional:
The relay module type RM.1 is available for the limit value monitoring.

TRANSDUCERS

Transducers for active power

(also available for reactive power)

Type MWu-3.1 **unequally loaded three wire three-phase AC**

Type MWu-4.1 **unequally loaded four wire three-phase AC**

The transducer types MWu-3.1 and MWu-4.1 are used to convert and separate the active power in three-phase alternating current networks into an impressed signal of direct current and direct voltage. The parameters to be measured reach an analogue multiplier via internal current transducers and voltage dividers. Inside the analogue multiplier, the instantaneous values of current and voltage are multiplied and converted into an average value of a direct voltage corresponding to the active power, inside a subsequent integrator. Sinusoidal as well as non-sinusoidal parameters of three-phase alternating current can be measured. The galvanic separation between the input signal and the output signal is ensured by means of an optocoupler. The downstream amplifiers supply the impressed signals of direct current and direct voltage.

- DOUBLE OUTPUT - Both outputs are idle and short-circuit protected.

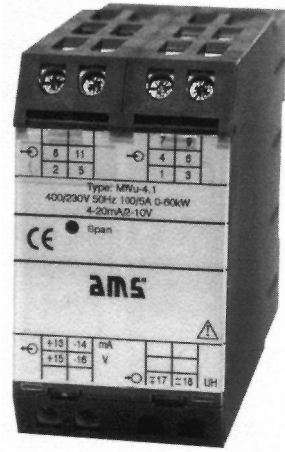

Input	active power at three-phase alternating current
Nominal values	MWu-3.1 unequally loaded three wire three-phase current ($P_s = U \times I \times 1.73$) 50 – 150 % of apparent power MWu-4.1 unequally loaded four wire three-phase current ($P_s = U \times I \times 1.73$) 50 – 150 % of apparent power
Nominal voltages	100 V, 110 V, 230 V, 400 V, 500 V, ± 20 %
Special voltage	690 V ± 20 %, only for grounded units (auxiliary voltage required)
Nominal current	1 A or 5 A
Internal consumption	voltage path approx. 2.5 VA current path approx. 0.3 VA
Nominal frequency	50 Hz, 60 Hz or 400 Hz
Permanent overload	current 2-fold I_n , voltage 1.2-fold U_n
Shock overload	current 20-fold I_n , voltage 2-fold U_n , max. 1 sec.
Output	double output for types MWu-3.1 or MWu-4.1
Standard output	0 – 20 mA and 0 – 10 V without auxiliary voltage or 4 – 20 mA and 2 – 10 V with auxiliary voltage
Special output	for import and export 20 – 0 – 20 mA and 10 – 0 – 10 V without auxiliary voltage
Load resistance	20 mA and 4 – 20 mA: 0 – 500 Ω 10 V and 2 – 10 V: max. 10 mA loadable
Auxiliary voltage	
Standard	230 V AC, ± 20 %, 45 – 65 Hz, 2.5 VA
Special versions	110 V AC, ± 20 %, 45 – 65 Hz, 2.5 VA
or	24 V DC, - 15 % to + 25 %, 2 W
or	36 – 265 V AC + DC, 2 VA
Accuracy	± 0.5 %
Mechanical data	
Housing	housing for 35 mm DIN rail, DIN EN 50022 width 45 mm
Housing material	PC (UL 94-V1), terminals PA (UL 94-V0)
Weight	approx. 360 g
Connection	screw connection max. 4 mm ²

TRANSDUCCERS

Type MWu-3.1

(unequally loaded three wire three-phase alternating current)

Type MWu-4.1

(unequally loaded four wire three-phase alternating current)

Transmission behaviour

Voltage influence	< 0.1 % at ± 10 % of nominal voltage
Frequency influence	< 0.3 % at 10 Hz frequency variation
Influence of phase angle	< 0.5 % at ± 90 degrees
Temperature range	- 15°C to + 55°C
Temperature influence	< 0.3 % at 10 K
Influence of auxiliary voltage	no
Influence of load resistance	no
Influence of external field	no (400 A/m)
Voltage ripple	< 30 mV _{ss}
Setting time	< 300 ms
Idle voltage	max. 24 V
Current limitation	max. 2-fold at override
Test voltage	4 kV between input-output-auxiliary voltage

Circuit diagrams

active power measurement

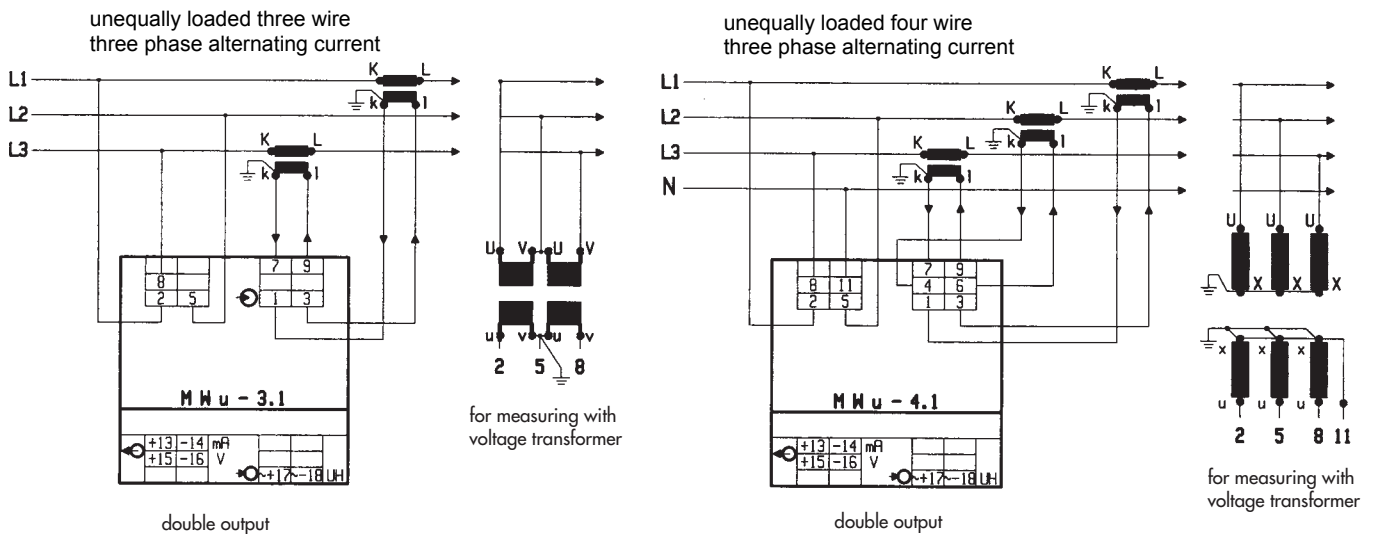

For double output, a connection of the two outputs is not permitted!

Scale drawing

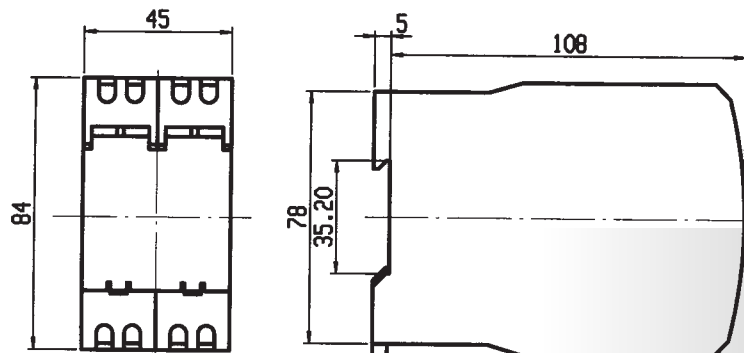

Optional:

The relay module type RM.1 is available for the limit value monitoring.

Transducers for direct current and direct voltage

Type MA-G.1 for direct current
Type MV-G.1 for direct voltage

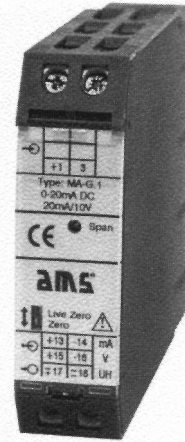

The transducer types MA-G.1 and MV-G.1 are used to convert and separate a direct current or direct voltage into an impressed signal of direct current and direct voltage. The measurement parameter reaches the amplifier, respectively the impedance converter via the input protection switching. The direct voltage obtained inside the impedance converter is converted into an impressed direct current and an impressed direct voltage. The galvanic separation is ensured by means of an optocoupler.

- DOUBLE OUTPUT - Both outputs are idle and short-circuit protected.

Input	direct current or direct voltage	
Nominal values	MA-G.1 from 0 – 100 μ A to 0 – 5 A (voltage drop 60 mV)	
Special value	MV-G.1 from 5 mV to 600 V 0 – 690 V only for grounded units ($R_i = 100 \text{ k}\Omega$ for input 5 mV to 1 V) (R_i approx. $100 \text{ k}\Omega/\text{V}$ for input > 1 V, max. $2 \text{ M}\Omega$)	
Permanent overload	current 2-fold I_n voltage 5-fold U_n , but max. 830 V	
Shock overload	current 20-fold, 1 sec. voltage 2-fold, 1 sec.	
Output	double output	
Standard	0 – 20 mA and 0 – 10 V reversible to	with auxiliary voltage
Special version	4 – 20 mA and 2 – 10 V 20 – 0 – 20 mA and 10 – 0 – 10 V	with auxiliary voltage
	load resistance at 20 mA and 4 – 20 mA mA: 0 – 500 Ω 10 V and 2 – 10 V: max. 10 mA loadable	
Auxiliary voltage		
Standard	230 V AC, $\pm 20 \%$, 45 – 65 Hz, 2.5 VA	
Special versions	110 V AC, $\pm 20 \%$, 45 – 65 Hz, 2.5 VA	
or	24 V DC, – 15 % to + 25 %, 2 W	
or	36 – 265 V AC + DC, 2 VA	
Accuracy	$\pm 0.5 \%$	
Switchover	The double output of the types MA-G.1 and MV-G.1 can be adjusted to 0 – 20 mA and 0 – 10 V or 4 – 20 mA and 2 – 10 V by using the front sliding switch (see operation manual).	
Mechanical data		
Housing	housing for 35 mm DIN rail, DIN EN 50022	
Housing material	PC (UL 94-V1), terminals PA (UL 94-V0)	
Weight	approx. 170 g	
Connection	screw connection max. 4 mm ²	

Type MA-G.1
Type MV-G.1

(direct current transducer)
(direct voltage transducer)

Transmission behaviour

Temperature range	- 15°C to + 55°C
Temperature influence	< 0.1 % at 10 K
Influence of auxiliary voltage	no
Influence of load resistance	no
Influence of external field	no (400 A/m)
Voltage ripple	< 15 mV _{ss}
Setting time	< 300 ms
	< 200 ms – special version –
Idle voltage	max. 24 V
Current limitation	max. 2-fold at override
Test voltage	4 kV between input-output-auxiliary voltage

Circuit diagrams

direct current - direct voltage

direct current measurement

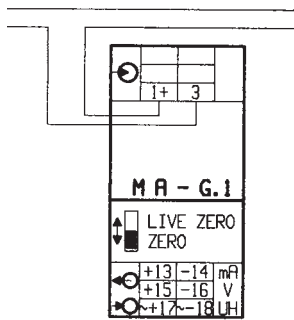

double output reversible

direct voltage measurement

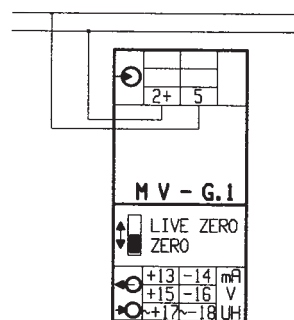

double output reversible

Scale drawing

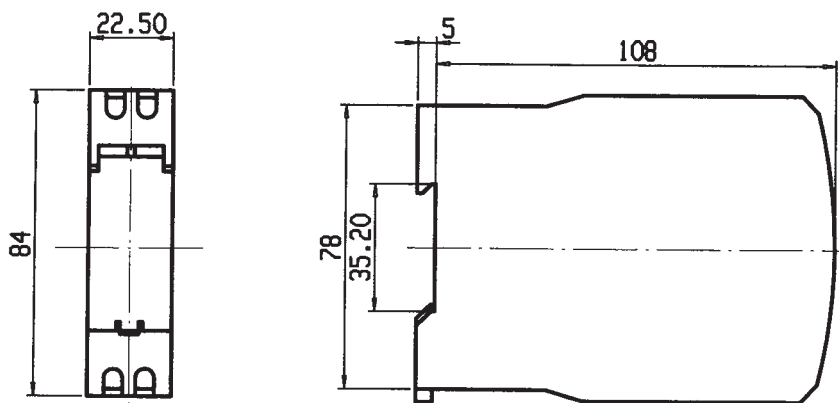

Optional:
 The relay module type RM.1 is available for the limit value monitoring.

Buffer amplifier Type MT-G.1

Direct current or direct voltage

The transducers type MT-G.1 are used to convert and separate a standard signal of direct current into an impressed signal of direct current and direct voltage. The standard signal reaches the amplifier, respectively the impedance converter via the input protection switching. The direct voltage obtained inside the impedance converter is converted into an impressed direct current and an impressed direct voltage. The galvanic separation is ensured by means of an optocoupler.

- DOUBLE OUTPUT - Both outputs are idle and short-circuit protected.

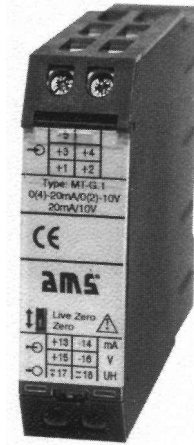

Input	direct current or direct voltage	
Standard signals	0 – 20 mA or 4 – 20 mA	
	0 – 10 V or 2 – 10 V	
Permanent overload	current 2-fold In	
	voltage 5-fold Un	
Shock overload	current: 20-fold, 1 sec.	
	voltage: 5-fold Un	
Output	double output	
Standard	0 – 20 mA and 0 – 10 V	with auxiliary voltage
	reversible to	
	4 – 20 mA and 2 – 10 V	
	load at 20 mA and 4 – 20 mA: 0 – 500 Ω	
	10 V and 2 – 10 V: max. 10 mA loadable	
Auxiliary voltage		
Standard	230 V AC, ± 20 %, 45 – 65 Hz, 2.5 VA	
Special versions	110 V AC, ± 20 %, 45 – 65 Hz, 2.5 VA	
	or 24 V DC, – 15 % to + 25 %, 2 W	
	or 36 – 265 V AC + DC, 2 VA	
Accuracy	± 0.5 %	
Switchover	The double output of the type MT-G.1 can be adjusted to	
	0 – 20 mA and 0 – 10 V or	
	4 – 20 mA and 2 – 10 V by using the front-side sliding switch	
	(see operation manual)	
Mechanical data		
Housing	housing for 35 mm DIN rail, DIN EN 50022	
	width 22.5 mm	
Housing material	PC (UL 94-V1), terminals PA (UL 94-V0)	
Weight	approx. 180 g	
Connection	screw connection max. 4 mm ²	

Type MT-G.1 (buffer amplifier)

Transmission behaviour

Temperature range	- 15°C to + 55°C
Temperature influence	< 0.1 % at 10 K
Influence of auxiliary voltage	no
Influence of load resistance	no
Influence of external field	no (400 A/m)
Voltage ripple	< 15 mV _{ss}
Setting time	< 200 ms
Idle voltage	max. 24 V
Current limitation	max. 2-fold at override
Test voltage	4 kV between input-output-auxiliary voltage

Circuit diagram

buffer amplifier

Input terminal configuration

signal	terminal no.
∅ - 20 mA	1 + 5
4 - 20 mA	2 + 5
∅ - 10 V	3 + 5
2 - 10 V	4 + 5

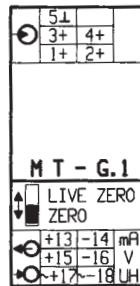

Scale drawing

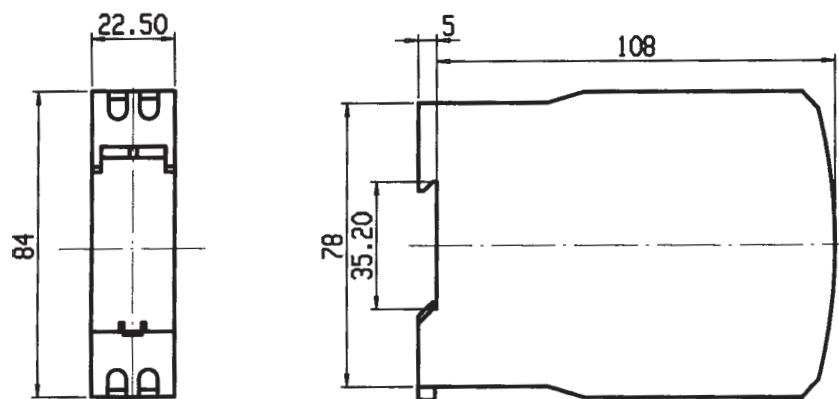

Optional:

The relay module type RM.1 is available for the limit value monitoring.

Temperature transducer for resistor thermometer Pt 100 Type MPt.1

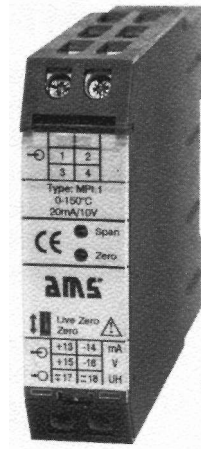

The transducers MPt.1 are used to convert and separate a temperature-affected resistance change into an impressed signal of direct current and direct voltage. The resistor thermometer PT 100 represents a temperature-dependent resistance. A steady measurement current reaches a measuring resistor being part of a bridge circuit, via the resistor thermometer. The direct voltage obtained inside the measuring resistor is linearized and amplified. Inside a subsequent circuit, it is converted into an impressed direct current and an impressed direct voltage. The galvanic separation is ensured by means of an optocoupler.

- DOUBLE OUTPUT - Both outputs are idle and short-circuit protected.

Input	resistor PT 100	
Nominal values	0 – 60°C, 0 – 100°C, 0 – 150°C, 0 – 300°C or 0 – 600°C	
Circuit	the constant current running through the sensor is approx. 2 mA	
Infeed	two-, three-, or four-wire circuit	
	two-wire: comparison 0 – 10 Ω by means of an installed spindle potentiometer	
	three-wire: no comparison required max. 100 Ω symmetrical	
	four-wire: no comparison required	
Output	double output	
Standard	0 – 20 mA and 0 – 10 V	with auxiliary voltage
	reversible to 4 – 20 mA and 2 – 10 V	
	load resistance at 20 mA and 4 – 20 mA: 0 – 500 Ω	
	10 V and 2 – 10 V: max. 10 mA loadable	
Auxiliary voltage		
Standard	230 V AC, ± 20 %, 45 – 65 Hz, 2.5 VA	
Special versions	110 V AC, ± 20 %, 45 – 65 Hz, 2.5 VA	
	or 24 V DC, – 15 % to + 25 %, 2 W	
	or 36 – 265 V AC + DC, 2 VA	
Accuracy	± 0.5 %	
Switchover	The double output of the type MPt.1 can be adjusted to 0 – 20 mA and 0 – 10 V or 4 – 20 mA and 2 – 10 V by using the front-side sliding switch (see operation manual).	
Mechanical data		
Housing	housing for 35 mm DIN rail, DIN EN 50022 width 22.5 mm	
Housing material	PC (UL 94-V1), terminals PA (UL 94-V0)	
Weight	approx. 150 g	
Connection	screw connection max. 4 mm ²	

Type MPt.1 (resistor thermometer Pt 100)

Transmission behaviour

Temperature range	- 15°C to + 55°C
Temperature influence	< 0.2 % at 10 K
Influence of auxiliary voltage	no
Influence of load resistance	no
Influence of external field	no (400 A/m)
Voltage ripple	< 30 mV _{ss}
Setting time	< 200 ms
Idle voltage	max. 24 V
Current limitation	max. 2-fold at override
Test voltage	4 kV between input-output-auxiliary voltage

Circuit diagrams

temperature measurement - resistor thermometer

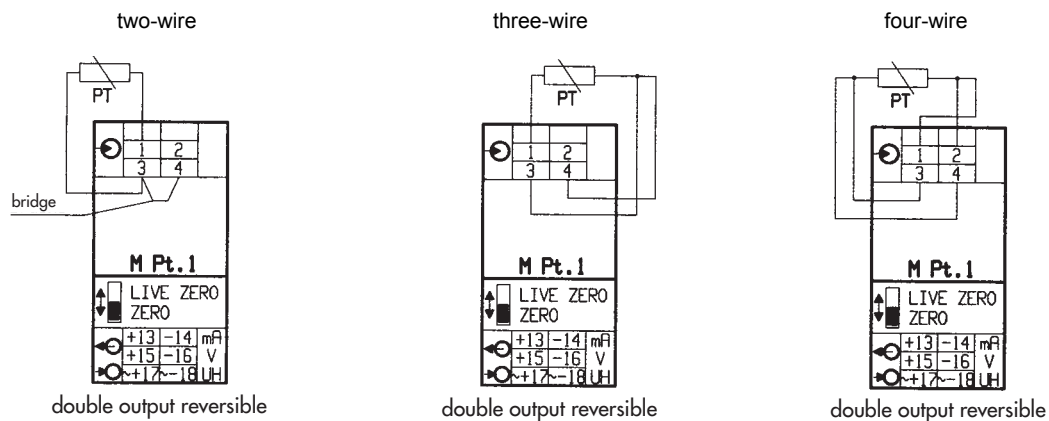

For double output, a connection of the two outputs is not permitted!

Scale drawing

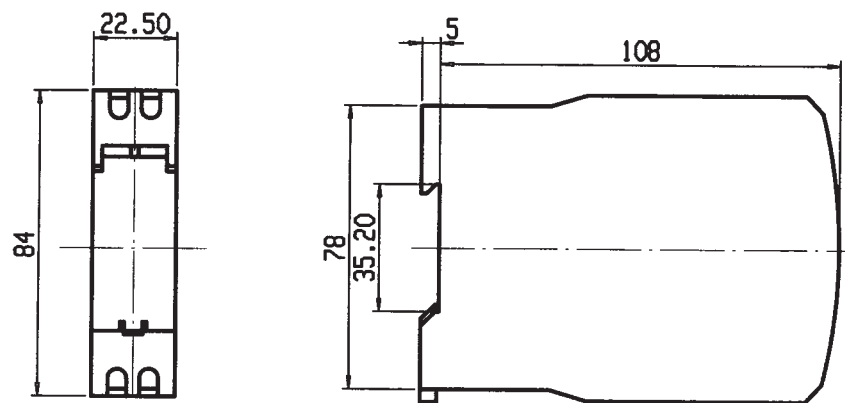

TRANSDUCERS

Optional:

The relay module type RM.1 is available for the limit value monitoring.

Temperature transducer for thermocouples Type MTh.1

The transducers MTh.1 are used to convert and separate a temperature-dependent voltage of a thermocouple into an impressed signal of direct current and direct voltage.

The thermocouple represents a temperature-dependent voltage source. This voltage is led to an amplifier with integrated compensation of cold junctions. After its linearization, the voltage is converted into an impressed direct current and an impressed direct voltage. The galvanic separation is ensured by means of an optocoupler.

- DOUBLE OUTPUT - Both outputs are idle and short-circuit protected.

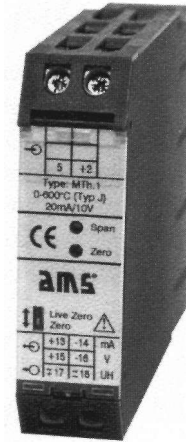

Input	thermal voltage	
Nominal values	element: Fe-CuNi	
	0 – 250°C, 0 – 400°C or 0 – 600°C	
or	element: NiCr-Ni	
	0 – 600°C, 0 – 900°C or 0 – 1200°C	
or	element: NiCrSi-NiSi	
	0 – 600°C, 0 – 900°C or 0 – 1300°C	
or	element: PtRh-Pt	
	0 – 1200°C, 0 – 1400 °C or 0 – 1600°C	
Special values	on demand	
Output	double output	
Standard	0 – 20 mA and 0 – 10 V	with auxiliary voltage
	reversible to	
	4 – 20 mA and 2 – 10 V	
	load resistance at 20 mA and 4 – 20 mA: 0 – 500 Ω	
	10 V and 2 – 10 V: max. 10 mA loadable	
Auxiliary voltage		
Standard	230 V AC, ± 20 %, 45 – 65 Hz, 2.5 VA	
Special versions	110 V AC, ± 20 %, 45 – 65 Hz, 2.5 VA	
or	24 V DC, – 15 % to + 25 %, 2 W	
or	36 – 265 V AC + DC, 2 VA	
Accuracy	± 0.5 %	
Switchover	The double output of the type MTh.1 can be adjusted to 0 – 20 mA and 0 – 10 V or 4 – 20 mA and 0 – 10 V by using the front-side sliding switch (see operation manual).	
Mechanical data		
Housing	housing for 35 mm DIN rail, DIN EN 50022 width 22.5 mm	
Housing material	PC (UL 94-V1), terminals PA (UL 94-V0)	
Weight	approx. 170 g	
Connection	screw connection max. 4 mm ²	

Type MTh.1 (thermocouples)

Transmission behaviour

Temperature range	- 15°C to + 55°C
Temperature influence	< 0.2 % at 10 K
Influence of auxiliary voltage	no
Influence of load resistance	no
Influence of external field	no (400 A/m)
Voltage ripple	< 30 mV _{ss}
Setting time	< 200 ms
Idle voltage	max. 24 V
Current limitation	max. 2-fold at override
Test voltage	4 kV between input-output-auxiliary voltage

Circuit diagram

temperature measurement - thermocouples

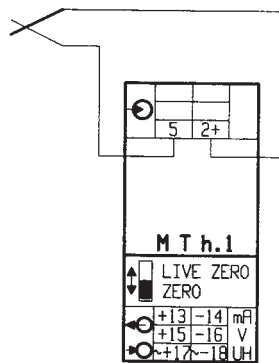

Scale drawing

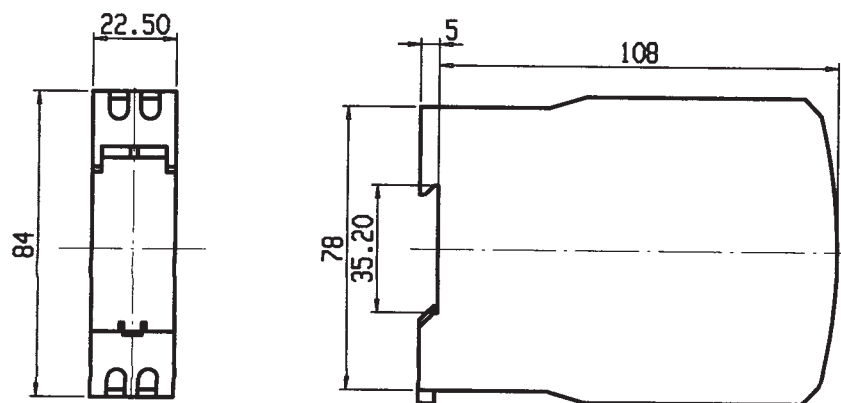

Optional:

The relay module type RM.1 is available for the limit value monitoring.

Transducer for remote resistance sensing Type MWi.1



The transducers MWi.1 are used to convert and separate a resistance change into an impressed signal of direct current and an impressed signal of direct voltage.

A constant measuring voltage is applied on the potentiometers three-wire circuit. The obtained measurement signal is amplified and converted into an impressed direct current and an impressed direct voltage. In two-wire circuits the measurement signal is obtained by means of a constant current.

The galvanic separation is ensured by means of an optocoupler.

- DOUBLE OUTPUT - Both outputs are idle and short-circuit protected.

Input	ohmic resistance	
Nominal values	three-wire circuit	
	0 – 100 Ω to 0 – 10 kΩ	
	or random interim values	
	two-wire circuit	
	0 – 100 Ω , 0 – 500 Ω or 0 – 1000 Ω	
Output	double output	
	0 – 20 mA and 0 – 10 V	with auxiliary voltage
	reversible to	
	4 – 20 mA and 2 – 10 V	
	load resistance at 20 mA and 4 – 20 mA: 0 – 500 Ω	
	10 V and 2 – 10 V: max. 10 mA loadable	
Auxiliary voltage		
Standard	230 V AC, ± 20 %, 45 – 65 Hz, 2.5 VA	
Special versions	110 V AC, ± 20 %, 45 – 65 Hz, 2.5 VA	
	or	24 V DC, – 15 % to + 25 %, 2 W
	or	36 – 265 V AC + DC, 2 VA
Accuracy	± 0.5 %	
Switchover	The double output of the type MTh.1 can be adjusted to	
	0 – 20 mA and 0 – 10 V or	
	4 – 20 mA and 2 – 10 V by using the front-side sliding switch	
	(see operation manual).	
Mechanical data		
Housing	housing for 35 mm DIN rail, DIN EN 50022	
	width 22.5 mm	
Housing material	PC (UL 94-V1), terminals PA (UL 94-V0)	
Weight	approx. 170 g	
Connection	screw connection max. 4 mm ²	

Type MWi.1 (remote resistance sensing)

Transmission behaviour

Temperature range	- 15°C to + 55°C
Temperature influence	< 0.2 % at 10 K
Influence of auxiliary voltage	no
Influence of load resistance	no
Influence of external field	no (400 A/m)
Voltage ripple	< 30 mV _{ss}
Setting time	< 300 ms
Idle voltage	max. 24 V
Current limitation	max. 2-fold at override
Test voltage	4 kV between input-output-auxiliary voltage

Circuit diagrams

remote resistance sensing

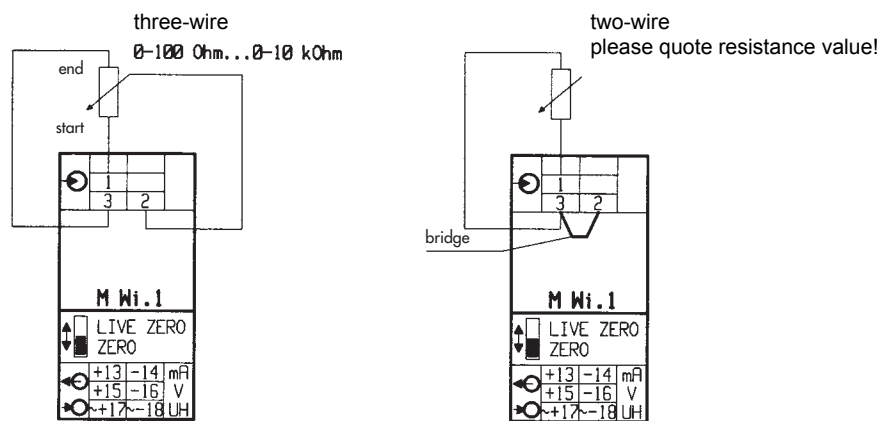

For double output, a connection of the two outputs is not permitted!

Scale drawing

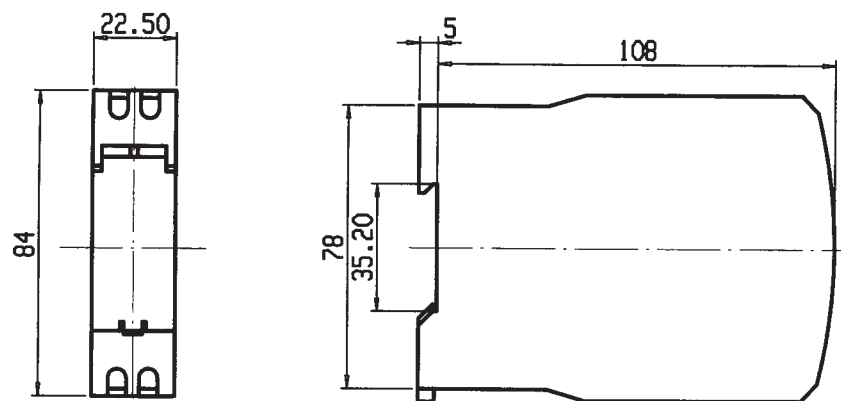

Optional:

The relay module type RM.1 is available for the limit value monitoring.

Relay module for transducer Type RM.1

The relay module RM.1 can only be put into operation combined with a transducer, and is used for the monitoring of the adjusted boundary value, triggering a relay when exceeded.

The value, generated by the transducer proportionally to the input, reaches a comparator and is compared with the configuration of the boundary value (0 - 100 %).

Subsequently, the reference value reaches a driver stage controlling the output relay and the LED display via an adjustable time circuit (0.1 to 10 sec.).

The relay module is fixed tightly to the transducer.

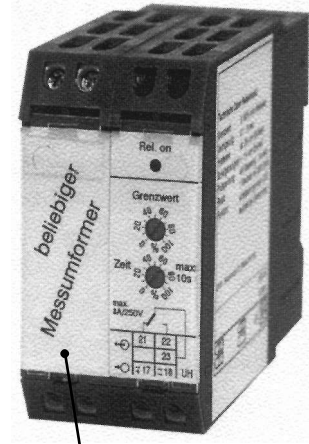

random transducer

Input	random transducer
Boundary value configuration	0 – 100 %
Trigger delay	0.1 to 10 sec., adjustable
Output	1 change-over contact
Function display	red LED
	lights up when relay is activated
Switchable load	max. 8 A, 250 V, 2000 VA
Switching characteristics	
Switching accuracy	± 1 % of the measurement range end value
Hysteresis	approx. 2 % of the measurement range end value
Temperature range	- 15°C to + 55°C
Temperature influence	< 0.1 % at 10 K
Test voltage	4 kV between measurement input and relay contact
Mechanical data	
Housing	housing for 35 mm DIN rail, DIN EN 50022 width 22.5 mm only in connection with a random transducer
Housing material	PC (UL 94-V1), terminals PA (UL 94-V0)
Weight	approx. 170 g plus transducer
Connection	screw connection max. 4 mm ²

When combined with a transducer without auxiliary voltage, an auxiliary voltage for RM.1 is required.

Circuit diagram

Relay module

